

Three Zone Two-Stage Heat Pump Control

Model H32



3 Zones

Installation and Operating Instructions



H32 PANEL FEATURES

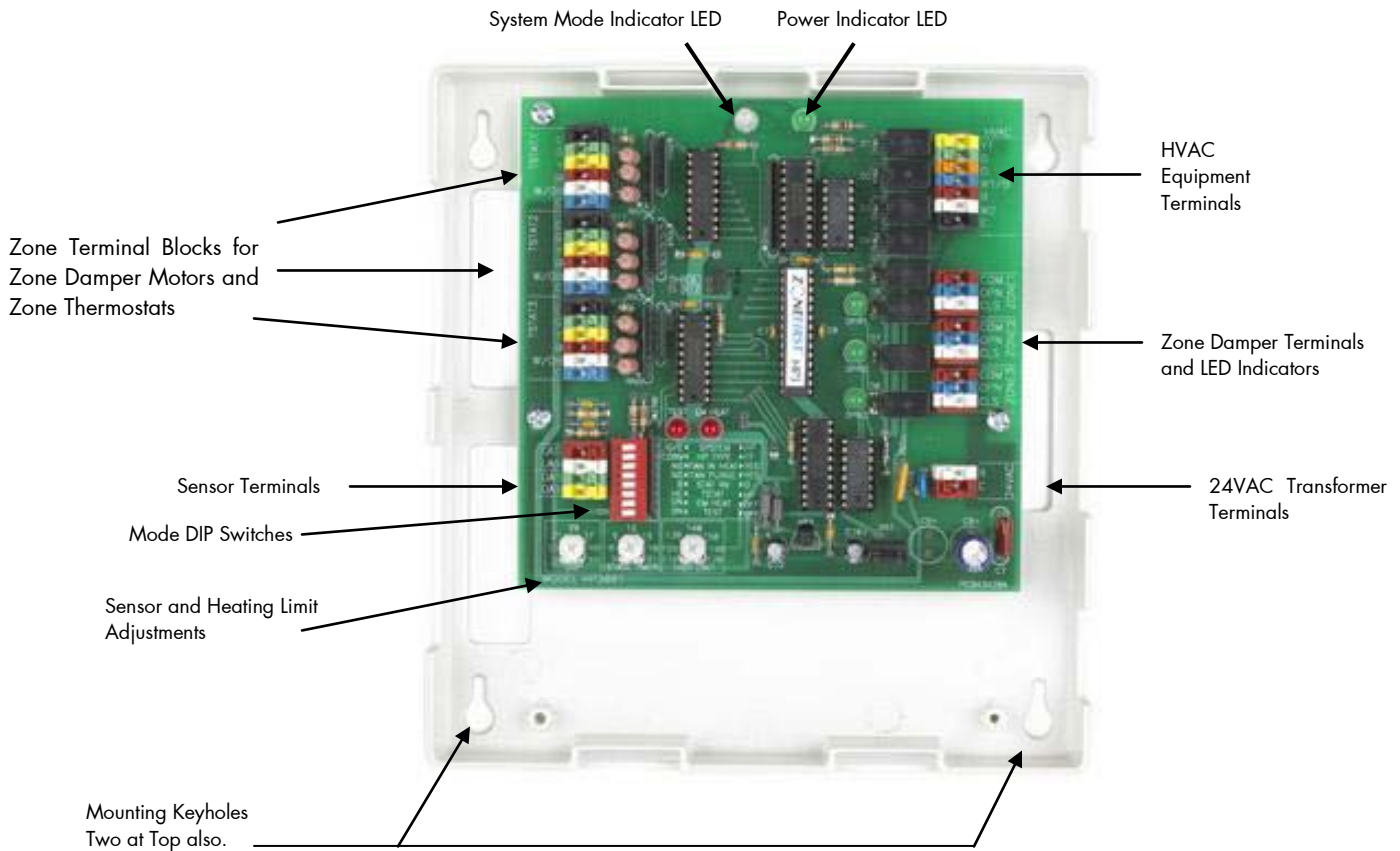

Table of Contents

Installation	3
Operation	3
Set-Up for Various HVAC Equipment	3
Leaving Air Sensor Air Sensor	4
Stager Timer	4
Wiring	4
Checkout	4
Troubleshooting	5
Wiring Diagram	6

INSTALLATION

The H32 Control is a three (3) zone control panel that can be used with conventional single stage, two stage heating and cooling and heat pumps with or without dual fuel. The H32 panel is the central control panel that all zone dampers, zone thermostats, HVAC Equipment Controls, power transformer, Outdoor Air and Leaving Air Sensor are wired.

When installing the H32 panel it is important to pick a central location where it is most convenient to bring all the wires. Most often this is at

the furnace or air handler. It is often the most convenient location and closest to power, the HVAC unit controls and the zone dampers when typically located at or near the plenum.

The H32 panel case is made of sturdy ABS plastic and can be mounted to any flat surface. It is recommended that the panel be mounted to a wall or return plenum and NOT on the furnace or plenum where it will be in contact with the excessive temperatures. The panel can be located in an attic space or in an enclosed cabinet of a rooftop unit. Insure the panel is not in direct exposure to the elements.

The cover easily removes from the case by pulling firmly and separating the cover from the case exposing the circuit board. There are 4 key-hole mounting points in each corner of the case. The case has openings in the rear of the case as well as the side for all wiring. Wiring can come from the back as well as the side in order to make a neat installation.

OPERATION

The H32 can be controlled by conventional single stage or heat pump thermostats. Each thermostat can then call for heating, cooling or the fan. This panel can control single stage gas-oil-electric heating and cooling, two stage heating and cooling and most heat pumps. This panel can control two stage/speed and dual/fossil fuel heat pumps.

When a call for either heating or cooling is made the panel will open the damper(s) to the zone(s) calling, close the damper(s) to those zones not calling, activate the appropriate controls for heating or cooling, whichever is being called and not accept any calls for the opposite mode.

Any calls for the opposite mode will be locked out until the initial mode is either satisfied or a period of time has elapsed that is sufficient for the first mode to satisfy, a maximum of 20 minutes. A unique sequence determines the time the unit has been running or needs to continue to run in order to adequately provide conditioning for each mode. If a particular mode has already been calling for 20 minutes or longer and an opposite call comes in the H32 will immediately drop the mode, enter the purge mode in order to dissipate the conditioned air into the zones calling before switching over to provide the new conditioning call to its zones.

When using the H32 to control two stage heating, the second stage is controlled based upon time after the first stage call from the thermostat. When any zone calls the panel's built-in timer begins and after the set period of time elapses the H32 will also activate the W2 for second stage heating. The Second Stage Timer is adjustable between 5 to 25 minutes after the first stage calls. Once the second stage is on, it will continue to run until the first stage is satisfied.

Once all zone thermostats are satisfied for heating and cooling, the H32 can now accept Fan calls allowing Continuous Air Circulation(CAC) in those zones where the thermostat's Fan Switch is set to ON. These zone dampers will be Open, while the dampers to the zones where the Fan Switch is set to AUTO will be CLOSED.

When all zone thermostats are satisfied for both Heating and Cooling, and all Fan switches are set to AUTO position, the HVAC unit will be off and all zone dampers will return to a normally open position. Once a zone calls for heating, cooling or fan, the dampers to the calling zones remain open and the dampers to the zones not calling will close.

Set-Up for Various HVAC Equipment

The H32 is factory set for conventional heating and cooling operation. The panel only needs to be configured when using with an electric furnace or heat pumps.

The panel configuration is done by setting the DIP switches in the top right of the panel. Other functions come by wiring for specific applications. Below is shown the most typical settings. Review each function for you application.

SYSTEM – G/E OR HP This switch sets the HVAC Output operation. In G/E the Y1 operates as first stage cooling only. In HP position Y1 makes as the compressor call for both heating and cooling.

HP Type – CONV or FF – This switch is used to determine the equipment output when the System switch is set to HP, this switch determines if the output will be for a conventional heat pump with electric back-up heat or fossil (dual) fuel mode.

FAN IN HEAT – YES or NO – This switch will activates the Fan on a call for Heat in the Yes position. In Off, the heating unit must activate the fan when the heat is called.

FAN PURGE – YES or NO – This switch determine if the Fan is kept on during the Purge Mode, after the end of each heat or cool call.

STAT RV – O or B – When using HP type thermostats this determines if the O or B terminal is wired to the W/OB terminal on each thermostat to determine if the call if for Heat (B) or Cool (O).

TSTAT – HC-HP Switch determines if conventional Heat/Cool thermostats or Heat Pump thermostats are being used for ALL zones. A conventional HC stat would have separate W and Y output for heating and cooling calls. A HP thermostat uses Y for both a heat and cool call and the O or B is used to determine whether the call is for Cooling (O) or Heating (B).

EM HEAT – This switch sets any heat call to call for the Emergency Heat. The Red EM HEAT LED on the panel will light only when this switch is ON. This is used when there is no EH switch on the thermostats.

TEST – This switch accelerates the panel timings in order to provide a quick checkout of all of the functions without having to wait the full time for each sequence.

One of the many features of the DIP switches is if at any time the equipment is changed from single stage to heat pump or vice versa the thermostats do not need to be changed with the equipment change. Changing the DIP switch settings is all that is needed.

Leaving Air and Outdoor Air Sensor

The Leaving Air Sensor, Model ZPS, is a remote sensor that is located in the supply air duct to sense the Leaving Air temperature of the HVAC Unit. The ZPS is a high limit protection for the heating and a low limit protection for the cooling. The ZPS protects the equipment in low air flow situations as well as when by-pass air is being directed back into the return air duct.

The heating limit is adjustable from 110°F to 170°F. The cooling limit is fixed at 45°F. When the ZPS senses heating above its set point, or cooling below its set point, the H32 will drop both all stages of heating or cooling. The ZPS must sense a 10°F fall for heating or rise for cooling before re-activating the first stages of heating or cooling. If two stage heating or cooling is being used the second stage timer will start again once the first stage is re-activated.

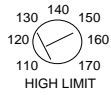

The ZPS requires 2 wires from the sensor to the ZPS terminals on the H32 panel.

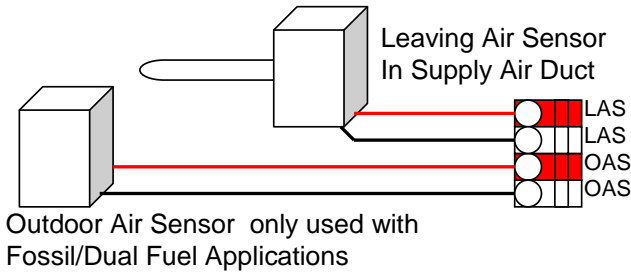

Outdoor Air Sensor - OAS

The Outdoor Air Sensor is used only when using a Heat Pump with Dual/Fossil Fuel back-up furnaces. The OAS senses the outdoor air temperature and switches the heating control between the heat pump and the fossil fuel furnace. The temperature set point for this is adjustable on the Outdoor Balance Point (OBP) dial on the control panel. It is adjustable from 5°F to 53°F.

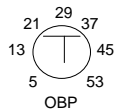

Stage Timer

The H32 has a built-in stage timer that eliminates the need and added cost of using two stage thermostats. On a call for either heating the timer begins. Setting the Stage Timer dial provides an adjustable time delay of 5 to 21 minutes between the first and second stage calls.

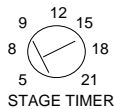

PURGE TIME

The H32 has a built-in Purge Time after each call is satisfied and provides a minimum off time before another call is initiated. The Purge Time is set at 2minutes after all calls for a particular mode are satisfied or when the Changeover Timer requires a changeover due to opposing calls.

After all calls are satisfied or the changeover timer activates, the Purge Timer begins and the heating or cooling, whichever was on, is deactivated. Typically the fan may be running during this time and the damper(s) to the last zone(s) calling will remain open to purge the conditioned air only into those zones that were calling for the conditioning. DIP Switch 5 can be set ON to keep the Fan running during the Purge mode in order to prevent the fan cycling off and back on between modes. In the instance where the Fan staying may create a draft, and the frequency of opposite calls is minimal this switch can be kept to OFF.

Minimum On Timer

The H32 also has a minimum on time whenever the compressor operates in order to prevent frequent short cycling. Once there is a call for cooling or the compressor on a heat pump, the H32 will hold that call for a period of 2 minutes.

CHANGEOVER TIMER

Whenever a call is made for either heating or cooling, the changeover timer is activated in order to track the amount of time heating or cooling is on. When an opposite call is made after a first call is made, the changeover timer calculates the amount of time the unit has already been supplying the first mode in order to determine how long it will hold off the opposite call. If an opposite call is made shortly after the first call, the opposite call may be held off for as much as 20 minutes. If the first call or subsequent calls for the first call mode has had that mode operating for up to 20 minutes already and an opposite call comes in after 20 minutes, the changeover timer will immediately recognize the opposite call, shutting off the current mode, enter the purge mode and automatically switch to the opposite mode.

The longer a call has been running up to 20 minutes, the shorter the wait time will be for an opposite call. If a call is over 20 minutes and an opposite call is made the changeover will be immediate following the purge time. This intelligent changeover timing makes the H32 unique to any other zoning system.

CHECKOUT

The H32 has unique features that simplify the checkout of the system and has LED readouts that constantly indicate the system operation. Once 24 Volt Power is applied to the panel the Green Power LED will illuminate. This will stay illuminated constantly when power is applied.

The System LED will provide several different indications based upon color and if it is flashing.

- First Stage Heat Call – RED
- Second Stage Heat Call – RED Flash 1/Second
- Heat Limit – Red/Amber Alternate Flashing
- First Stage Cool Call – GREEN
- Second Stage Cool Call – GREEN Flash 1/second
- Cool Limit - GREEN/Amber Alternate Flashing
- FAN ON - AMBER
- PURGE - AMBER Flashing

Each zone has its own small Green indicator LED next to each zone relay. This light is lit when the specific zoning is calling for the mode shown on the System LED.

WIRING

The H32 is very simple to wire and requires only a minimum number of connections. The H32 terminal blocks are color coded and screwless for all wires to be easily pushed into their respective terminal by de-pressing the button for each point and releasing once the wire is seated. (Solid wire can often just be pushed into the terminal without de-pressing the button.) To remove the wire, just press its button again and remove the wire.

Zone Dampers – The H32 can power any 24VAC damper, either 2 wire or 3 wire. See specific wiring instructions with the damper or inside panel cover. The three damper motor contacts are for 24VAC power are COM (Common), OPN (Open) and CLS (Closed)

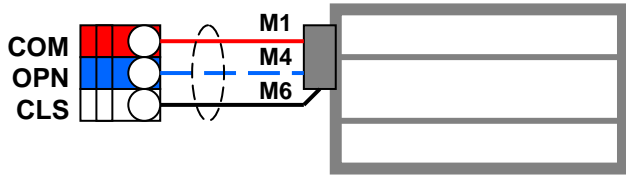

Zone Thermostats – The thermostats wiring will be for Conventional single stage (Y-G-R-W-C) or Heat Pump (Y-G-R-E-C and O or B). See Wiring Diagram 1 and 2 for each type of thermostat.

WIRING DIAGRAM 1 – Conventional Thermostats

CONVENTIONAL THERMOSTAT

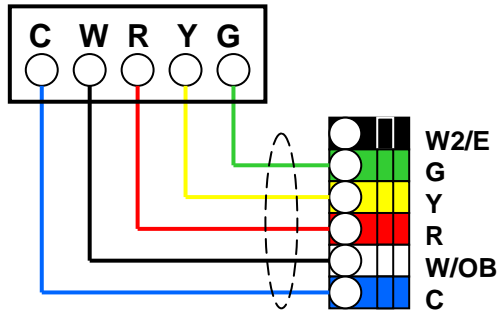

WIRING DIAGRAM 2 – Heat Pump Thermostat

HEAT PUMP THERMOSTAT

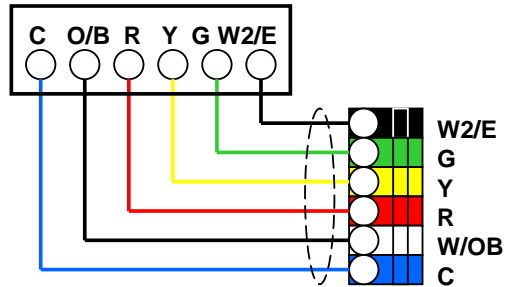

WIRING DIAGRAM 3 - HVAC Equipment – Conventional Single Stage and Two-Stage Equipment

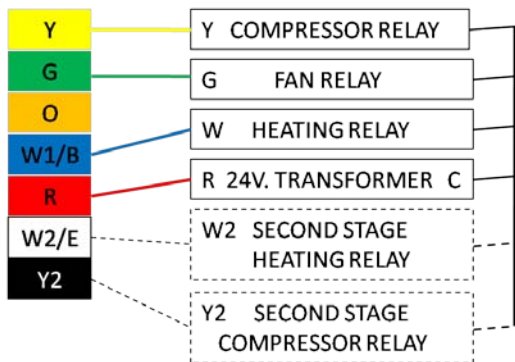

WIRING DIAGRAM 5 - Single Speed Compressor Heat Pump

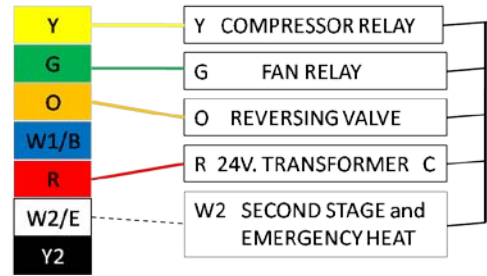

WIRING DIAGRAM 6 - Two Speed Compressor Heat Pump

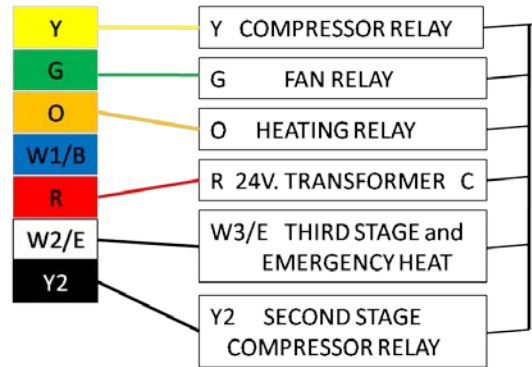

TROUBLESHOOTING

The H32 is a very simple control to troubleshoot, especially with the LED indicators. The only other device needed is a simple Volt/Ohm meter. Almost all problems can be traced to an external component or wiring to the H32. The following procedures can help isolate the problem.

Zone(s) Not Calling

Each zone has a Green LED next to the zone relay when it is calling and that calling is being recognized by the H32. If a zone is supposed to be calling and the Zone LED is not on, check for 24VAC across the thermostat terminal C and the Y, if a Cool call, W if a Heat Call, or G if a Fan call. If there is no voltage here at the panel the panel is not getting the signal from the thermostat. The problem is mis-wiring, a broken wire or a problem in the thermostat. To check the zone on the panel, place jumper from R to Y, R to W or R to G to see that the panel is operating properly.

Zone(s) Will Not Shut Off

If a zone will not stop calling the Zone LED should still be on. Depending on the call disconnect the Y, W or G wire from the terminal strip. The zone will drop out. Check the thermostat wiring for a mis-wiring or short that keeps the zone calling.

Damper Motor Checkout

To check out the dampers, the panel provides 24VAC to the COM and OPEN. When the damper is to be closed, there will be 24VAC to COM and CLOSE. When any zone is calling and its Green LED is ON, there is 24VAC across COM and OPEN. The only time a damper will close is when another zone is calling and its zone is not calling. In this instance there will be 24VAC across COM and CLOSE.



H32

Wiring Diagram

For Single Stage, Two Stage & Heat Pumps
(Wiring Shown for Heat Pump)

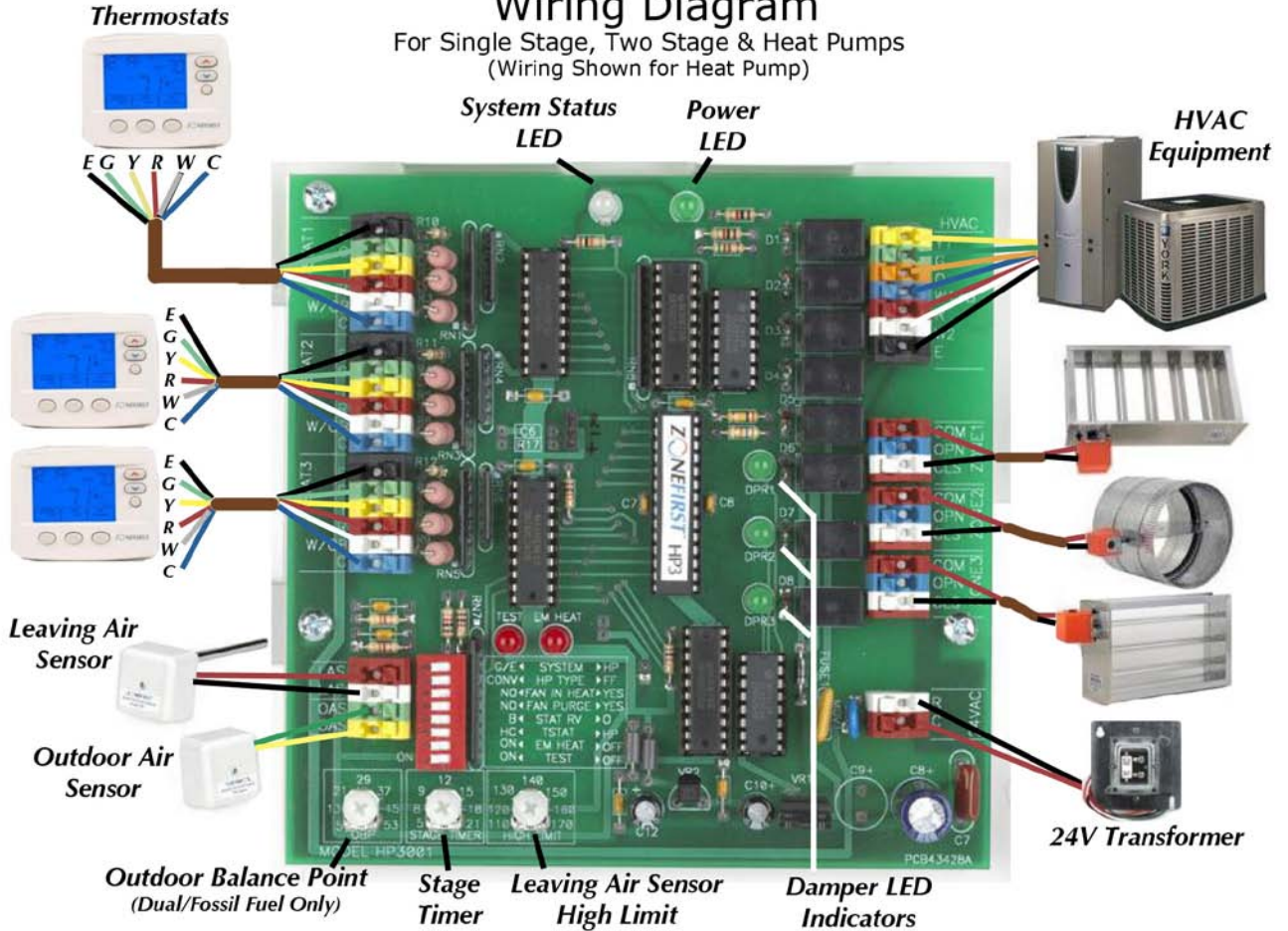

SYSTEM OPERATION: The H32 Zone Control can be used with conventional single stage, two stage, or electric and dual fuel heat pumps. Wiring is shown above a electric heat pump. See panel instructions for wiring of different types of HVAC Systems. When either zone calls for heating, cooling and/or the fan only, the satisfied zone damper(s) close and the H32 activates the appropriate HVAC Controls. When all zones are satisfied, all dampers open. The top right LED indicates power to the panel at all times. The System LED is RED for Heat Call, Green for a Cool Call and both light Yellow for a Fan Only call or in a time delay. Each zone damper has an LED that lights whenever the zone damper is to be open. For further information refer to the installation instructions with this panel or on our website. Scan for more information.

For on the job assistance call 1-877-FIRSTZONE (347-7896), M-F, 7AM-5PM, ET.

Or visit us at www.zonefirst.com



55 Bushes Lane • Elmwood Park, New Jersey 07407-3204 USA
Telephone 1.201.794.8004 FAX 1.201.794.1359
www.zonefirst.com info@zonefirst.com