

SUBMITTAL INFORMATION

Mechanical Joint Retainer (*UFR1500R-ZA-x-U style*)

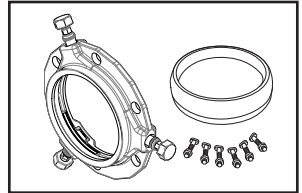

3" - 6" SERIES UFR1500R RAPID INSTALL CIRCLE-LOCK MECHANICAL JOINT RESTRAINT FOR C900 AND IPS PVC WITH ACCESSORIES AND SO-EZ GASKET

SO-EZ™ gasket -
(ANSI/NSF Standard 61 approved)

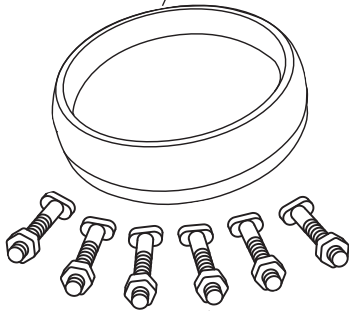

High strength, low alloy T-bolts & nuts (AWWA C111)

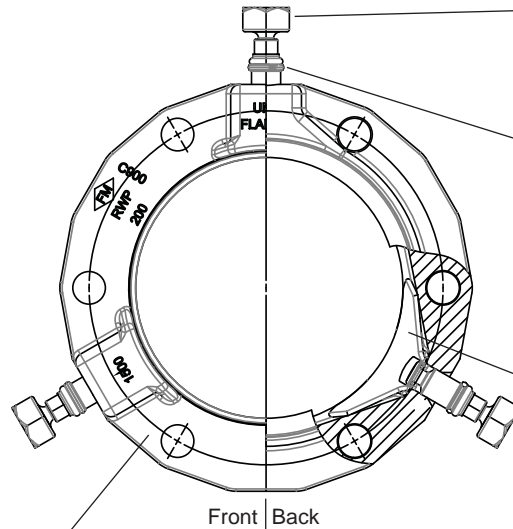

Gland body is of High Strength Ductile Iron per ASTM A536, Grade 65-45-12. Compatible with all mechanical joints conforming to ANSI / AWWA C111 / A21.11.

Ductile iron actuating screw, with the Auto-Tork break-away head design, insures proper torque during installation.

Safety stop insures ring segments can never be over-tightened.

Ring Segments are ductile iron per ASTM A536

Auto-Tork Bolt

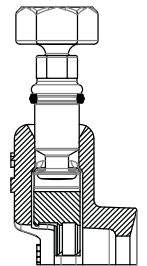

Restraint Segment

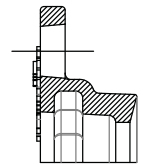

Bolt Hole Cross Section

NOM. PIPE SIZE	O.D.	CATALOG NUMBER	NO. OF RESTRAINT SEGMENTS	APPROX. WEIGHT (LBS.)	P1*	P2**		BC	D	PRESSURE RATING					✓ SUBMITTED ITEM(S)
						C900	IPS			C900		ASTM D2241			
										DR-14	DR-18	DR-25	SDR-21	SDR-26	
3"	3.50"	UFR1500R-ZA-3-U	2	10.70	11.50"	-	9.00"	6.19"	4.06"	-	-	-	200 PSI	160 PSI	
4"	4.50"-4.80"	UFR1500R-ZA-4-U	2	8.06	13.00"	10.25"	9.25"	7.50"	4.90"	305 PSI	235 PSI	165	200 PSI	160 PSI	
6"	6.63"-6.90"	UFR1500R-ZA-6-U	3	11.37	15.13"	12.17"	11.90"	9.50"	7.00"	305 PSI	235 PSI	165	200 PSI	160 PSI	

*Maximum O.D. of gland on pipe before Auto-Tork heads are removed (as shipped).

**Maximum O.D. of gland on pipe after Auto-Tork heads are removed.

FEATURES

- Fits C900 PVC and ASTM D2241 IPS PVC
- "Auto-Tork" actuating screws with heads specially designed to twist off at the correct installation torque, leaving a hex head in case future system maintenance or removal is required
- Restraining segments are mechanically retained in pockets
- Series 1500 eliminates the need to pour expensive and time consuming concrete thrust blocks
- FM approved for use on listed and approved C900 PVC pipe
- Not approved for use on C909 PVC
- Gland, screws and segments are black epoxy coated using the e-coat process
- Gland colored red for identification purposes
- Made in the U.S.A.

The Ford Meter Box Company considers the information in this submittal form to be correct at the time of publication. Item and option availability, including specifications, are subject to change without notice. Please verify that your product information is current.



The Ford Meter Box Company, Inc.

P.O. Box 443, Wabash, Indiana U.S.A. 46992-0443

Phone: 260-563-3171 / Fax: 800-826-3487

Overseas Fax: 260-563-0167

<http://www.fordmeterbox.com>



Submitted By:

11/05/12