

SUBMITTAL INFORMATION

Mechanical Joint Retainer (UFR1500R-CA-x-I style)

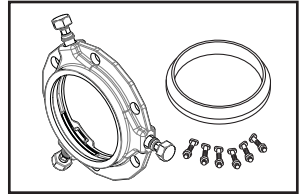

4" - 6" SERIES UFR1500R RAPID INSTALL CIRCLE-LOCK MECHANICAL JOINT RESTRAINT FOR C900 PVC

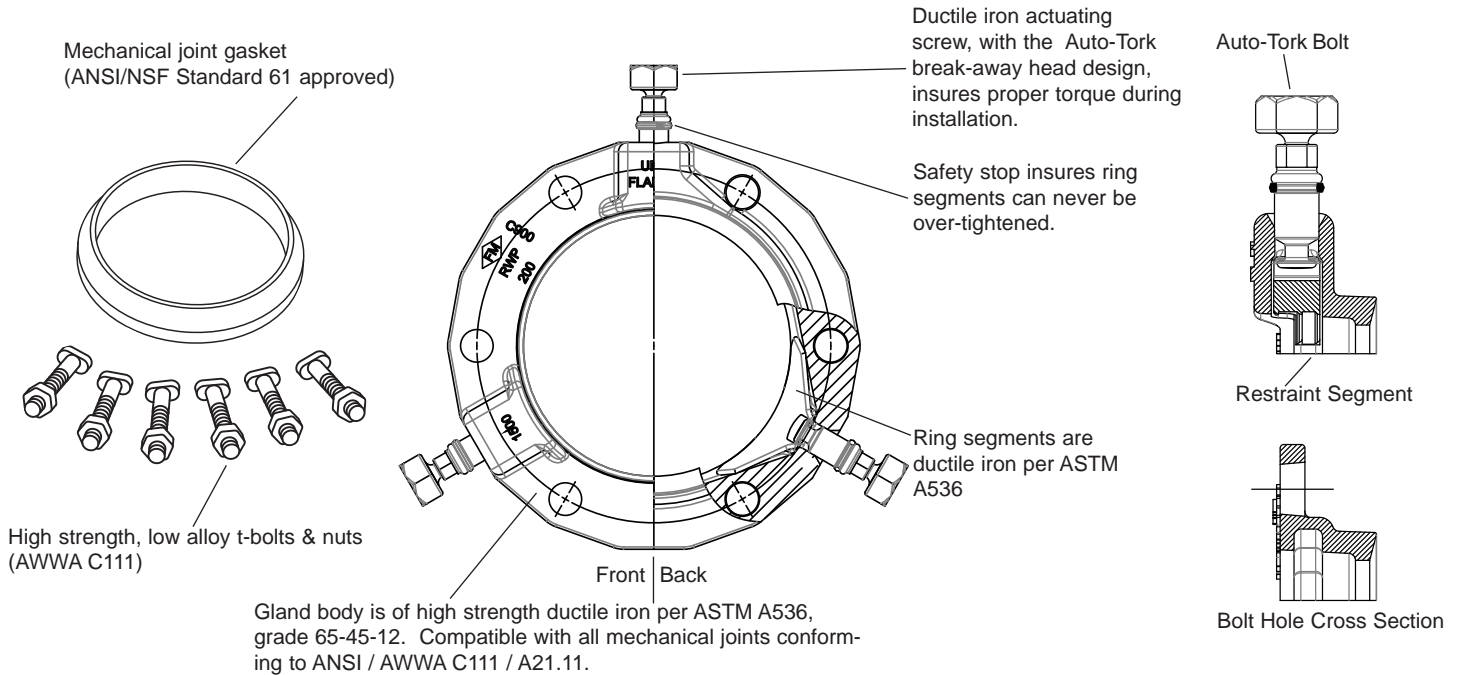

NOM. PIPE SIZE	O.D.	CATALOG NUMBER	No. OF RESTRAINT SEGMENTS	APPROX. WEIGHT (LBS.)	P1*	P2**	BC	D	PRESSURE RATING			✓ SUBMITTED ITEM(S)
									C900			
									DR-14	DR-18	DR-25	
4"	4.80"	UFR1500R-CA-4-I	2	12.50	13.00	10.25	7.50	4.90	305 PSI	235 PSI	165 PSI	
6"	6.90"	UFR1500R-CA-6-I	3	18.00	15.13	12.17	9.50	7.00	305 PSI	235 PSI	165 PSI	

*Maximum O.D. of gland on pipe before Auto-Tork heads are removed (as shipped).

**Maximum O.D. of gland on pipe after Auto-Tork heads are removed.

FEATURES

- Fits C900 PVC
- "Auto-Tork" actuating screws with heads specially designed to twist off at the correct installation torque, leaving a hex head in case future system maintenance or removal is required
- Restraining segments are mechanically retained in pockets
- Series 1500 eliminates the need to pour expensive and time consuming concrete thrust blocks
- UL listed and FM approved for use on listed and approved C900 PVC pipe
- Not approved for use on C909 PVC
- Imported ductile iron castings
- Gland, screws and segments are black epoxy coated using the e-coat process
- Gland colored red for identification purposes
- Assembled, inspected and packaged in the U.S.A.

The Ford Meter Box Company considers the information in this submittal form to be correct at the time of publication. Item and option availability, including specifications, are subject to change without notice. Please verify that your product information is current.



The Ford Meter Box Company, Inc.

P.O. Box 443, Wabash, Indiana U.S.A. 46992-0443

Phone: 260-563-3171 / Fax: 800-826-3487

Overseas Fax: 260-563-0167

www.fordmeterbox.com



06/26/15

Submitted By: