

# SUBMITTAL INFORMATION

## Uni-Flange Retainer (UFR1400-D-x-I style)

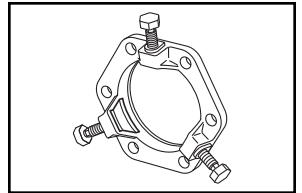

### WEDGE ACTION SERIES 1400-D RETAINER GLAND FOR DUCTILE IRON PIPE

Ductile iron wedge actuating screw, with the Auto-Tork break-away head design, insures proper torque during installation.

Gland body is of high strength ductile iron per ASTM A536, Grade 65-45-12. Compatible with all mechanical joints conforming to ANSI/AWWA C111/A21.11.

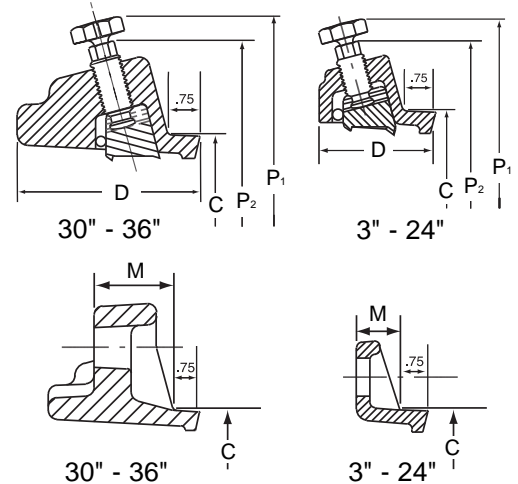
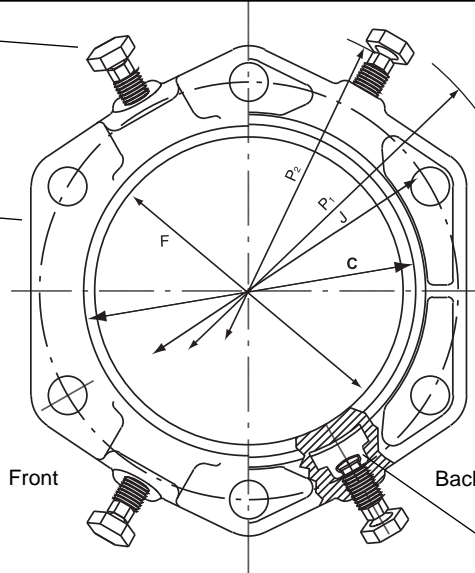

Wedges are ductile iron and heat treated to a hardness of 370 BHN minimum.

NOM. PIPE SIZE	O.D.	CATALOG NUMBER	PRESSURE RATING (PSI)	NO. OF WEDGES	APPROX. WEIGHT (LBS.)	P1*	P2**	C	D	F	M	J	✓ SUBMITTED ITEM(S)
3	3.96	UFR1400-D-3-I	350	2	6.0	11.04	9.06	4.84	2.65	4.06	0.68	6.19	
4	4.80	UFR1400-D-4-I	350	2	7.5	11.9	10.0	5.92	2.65	4.90	0.88	7.50	
6	6.90	UFR1400-D-6-I	350	3	11.0	14.0	12.1	8.02	2.65	7.00	0.88	9.50	
8	9.05	UFR1400-D-8-I	350	4	14.5	16.2	14.3	10.17	2.65	9.15	1.10	11.75	
10	11.10	UFR1400-D-10-I	350	6	23.0	18.2	16.3	12.22	2.75	11.20	1.10	14.00	
12	13.20	UFR1400-D-12-I	350	8	28.5	20.3	18.4	14.32	2.75	13.30	1.10	16.25	
14	15.30	UFR1400-D-14-I	350	10	46.0	22.9	20.9	16.40	3.00	15.50	1.50	18.75	
16	17.40	UFR1400-D-16-I	350	12	52.0	25.0	23.0	18.50	3.00	17.60	1.56	21.00	
18	19.50	UFR1400-D-18-I	250	12	69.0	28.1	25.8	20.60	3.05	19.70	1.65	23.25	
20	21.60	UFR1400-D-20-I	250	14	76.0	30.2	27.9	22.70	3.10	21.82	1.70	25.50	
24	25.80	UFR1400-D-24-I	250	16	90.0	34.4	32.1	26.90	3.20	26.04	1.85	30.00	
30	32.00	***UFR1400-D-30-I	250	20	221.0	40.6	38.6	33.29	4.30	32.29	2.25	36.88	
36	38.30	***UFR1400-D-36-I	250	24	260.0	46.9	44.9	39.59	4.50	38.62	2.25	43.75	

\* Maximum O.D. of gland on pipe before break-away heads have been removed (as received).

\*\* Maximum O.D. of gland on pipe after wedges have been activated and break-away heads have been removed.

\*\*\* 30 - 36" sizes include a Uni-Seal gasket.

### FEATURES

- Eliminates the need of costly and time consuming concrete thrust blocks and corrosion susceptible steel tie rods
- "Auto-Tork" wedge actuating screws assure proper installation
- Wedges are contoured to fit the pipe
- Gland, screws and wedges are black e-coated
- Imported ductile iron castings
- Assembled, inspected and packaged in the U.S.A.
- 2:1 safety factor at rated pressure
- FM Approved (4"-12") and UL Listed (4"- 48")

The Ford Meter Box Company considers the information in this submittal form to be correct at the time of publication. Item and option availability, including specifications, are subject to change without notice. Please verify that your product information is current.



**The Ford Meter Box Company, Inc.**

P.O. Box 443, Wabash, Indiana U.S.A. 46992-0443

Phone: 260-563-3171 / Fax: 800-826-3487

Overseas Fax: 260-563-0167

www.fordmeterbox.com

01/30/15

Submitted By: