



100 Royal Way
 Temple, GA 30179
 Phone (800) 520-6593

SPECIFICATION DATA SHEET

MODEL No. 501E/S
End/Side Outlet
Insulated Box

Date:12-8-14

DIMENSIONAL DATA

<u>Register</u> <u>Size AxB</u>	<u>Collar</u> <u>Size</u>	<u>R4/R6 Actual</u>		<u>R8 Actual</u>	
		<u>Dimensions</u> <u>AxB</u>	<u>Height</u> <u>C</u>	<u>Dimension</u> <u>AxB</u>	<u>Height</u> <u>C</u>
8x4	4, 5	10x6	6"	11x7	7"
10x6	5, 6	12x8	7"	13x9	8"
12x6	6, 7	14x8	8"	15x9	9"
12x8	8	14x10	9"	15x11	10"
14x6	8	16x8	9"	17x9	10"

FABRICATION DATA

Material:

ASTM-A653 CS Type B Galvanized Steel - 30GA
 G-30 Coating LFG Chemical Treatment

Assembly:

Ceiling Boot assembled with C-115 2/16" zinc coated steel rivets, has a rectangular opening with a 1/2" drywall flange. The collar is 3 1/2" tall roll formed 30GA steel with 1/4" bead for flex attachment & 1/8" finished hem on collar.

Insulation:

Knauf Equipment Liner M with ECOSE® Technology
 Available Thickness: R4 - 1", R6 - 1½", & R8 - 2"

ASTM C 1071, Type I, Flexible (replaces obsolete Federal Specification HH-I-545B.) NFPA 90A/90B, ASTM C 665/1617
 Temperature Range (ASTM C 411), Microbial Growth (ASTM C1338, G21)



Model 501E - End Outlet Insulated Box (shown)

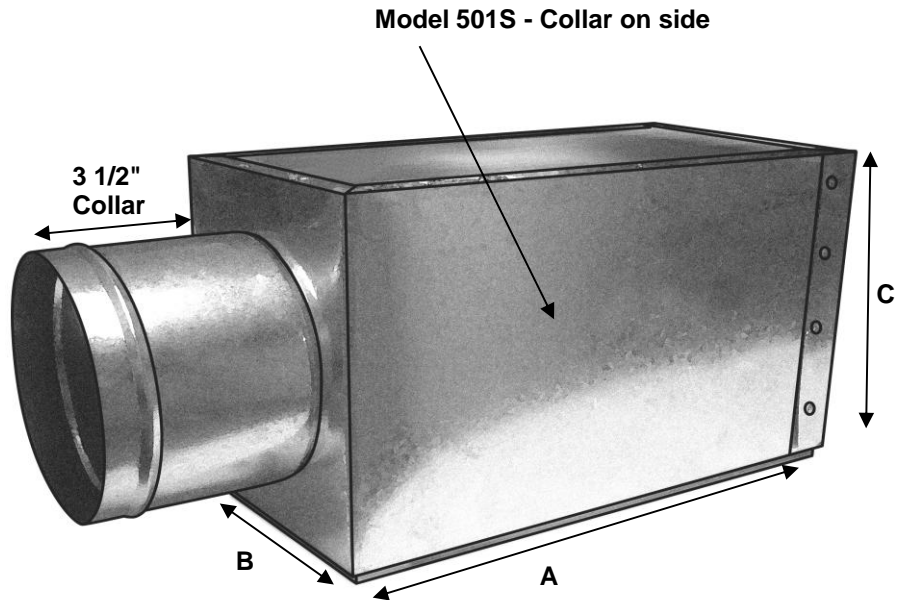

Superior Quality, Superior Service, Superior Value.. that's the Royal Advantage