

# Commercial High-Efficiency Condensing Units



**R410A**



**10 & 12.5 TON MODEL  
[35.2 & 44.0 kW]**



**15 & 20 TON MODEL  
[52.8 & 70.3 kW]**



10 THROUGH 20 NOMINAL TON UNITS  
[35.2 THROUGH 70.3 kW]  
RAWL- SERIES

# TABLE OF CONTENTS

Model Number Designation .....2  
 Accessories .....3  
 Standard Unit Features .....3-4  
 Selection Procedure  
     Matched Systems .....5  
 Gross Capacity and Power Tables .....6-7  
 Unit Dimensions .....8-9  
 AHRI Ratings .....10

Electrical & Physical Data Table .....11  
 Cooling Performance Data .....12-15  
 Installation .....16  
 Limited Warranty .....16  
 Piping .....17-18  
 Wiring Schematic .....19-20  
 Sequence of Operation .....21  
 Sample Specifications .....22

## WHY USE A HIGH EFFICIENCY, AIR COOLED SPLIT SYSTEM?

- The size ranges offered by Ruud® allow you to mix or match components to meet actual job requirements, thus eliminating the need to use oversized or undersized equipment. Equipment sized to meet the actual load will provide better operating economy, better humidity control, and longer equipment life.
- With an air cooled system, you have no water or sewer connections to make, and no troublesome and costly water treatment problems.
- Since the condensing unit is located outside the building, and the low profile air handling unit can be installed in the drop ceiling or in the conditioned space, you will not need a separate equipment room which takes up valuable building space.
- Remote mounting of the already quiet condensing unit keeps the compressor and condenser fan noise outside, and the vertical discharge fans carry the sound up and away from the surrounding area.
- Because of the simple design of the Ruud condensing unit, installation is quick and simple, and very little maintenance is required.
- Energy Efficiency Ratings (EER's) to 11.2!

## MODEL NUMBER DESIGNATION

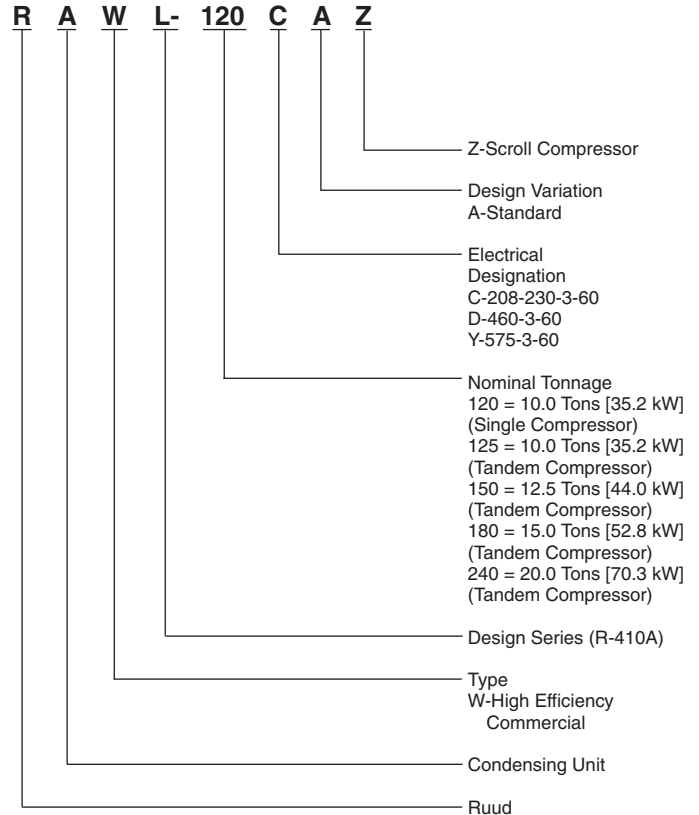

[ ] Designates Metric Conversions

# CONDENSING UNIT ACCESSORIES

ACCESSORY DESCRIPTION	MODEL NUMBER	SIZES USED ON
Sight Glass	RXAG-A048	120, 125
Sight Glass	RXAG-A020	180, 240
Liquid Line Solenoid Valve*	RXAV-CD120	120, 125, 150
Liquid Line Solenoid Valve*	RXAV-CD180	180, 240

\*Cannot be used as a pump down solenoid.

## STANDARD UNIT FEATURES

**CABINET**—Galvanized steel with a durable powder paint finish. Stamped louvered panels offer 100% protection for the condenser coil.

**COMPRESSOR**—The Scroll Compressor is hermetically sealed with internal overload protection and durable insulation on motor windings. The entire compressor is mounted on rubber grommets to reduce vibration and noise.

**CONDENSER COIL**—Constructed with copper tubes and aluminum fins mechanically bonded to the tubes for maximum heat transfer capabilities.

**BASE PAN**—Galvanized steel with powder paint finish.

**REFRIGERANT CONNECTIONS**—Field piping connections are made through a fixed panel. This allows removal of access panels after piping connections have been made.

**CRANKCASE HEATERS**—Standard, all models. Prevents refrigerant migration to compressor(s).

**LOW AMBIENT CONTROL**—A pressure sensitive fan cycling control to allow unit operation down to 0°F [-17.8°C] is standard.

**SERVICE VALVES**—Standard on liquid and suction lines. Allows outdoor section to be isolated from indoor coil.

**SERVICE ACCESS**—Control box as well as the compressor and other refrigerant controls are accessible through access panels. Control box may be open without affecting the normal operation of the unit. Condenser fan motors are accessible by removing wire grilles.

**FILTER DRIER**—Standard (uninstalled) on all models. Helps ensure refrigerant cleanliness.

**TRANSFORMER**—Step-down type, line to 24 volts. Provides control circuit voltage.

**CONTACTOR**—The contactor is an electrical switch which operates the compressor and condenser fans.

**HIGH PRESSURE CONTROL**—Opens the contactor circuit on high refrigerant pressure; manual reset.

**LOW PRESSURE CONTROL**—Stops compressor operation in the event of loss of refrigerant.

**CONDENSER FAN MOTOR (Direct Drive)**—Ball bearing 1075 RPM motors are mounted to minimize vibration and noise problems. These are permanent split capacitor types.

**TESTING**—All units are run tested at the factory prior to shipment. Units are shipped with a holding charge of nitrogen.

**EXTERNAL GAUGE PORTS**—Allows pressures to be checked without removing access panel.

**COIL LOUVERS**—Helps prevent damage to outdoor coils.

**TIME DELAY**—Supplied on tandem compressor models to provide a delay between stages.

**EQUIPMENT GROUND**—Lug for field connection of ground wire.

[ ] Designates Metric Conversions

# 10, 12.5, 15 & 20 TON [35.2, 44.0, 52.8 & 70.3 kW] MODELS

## COMPRESSOR COMPARTMENT

RAWL-120

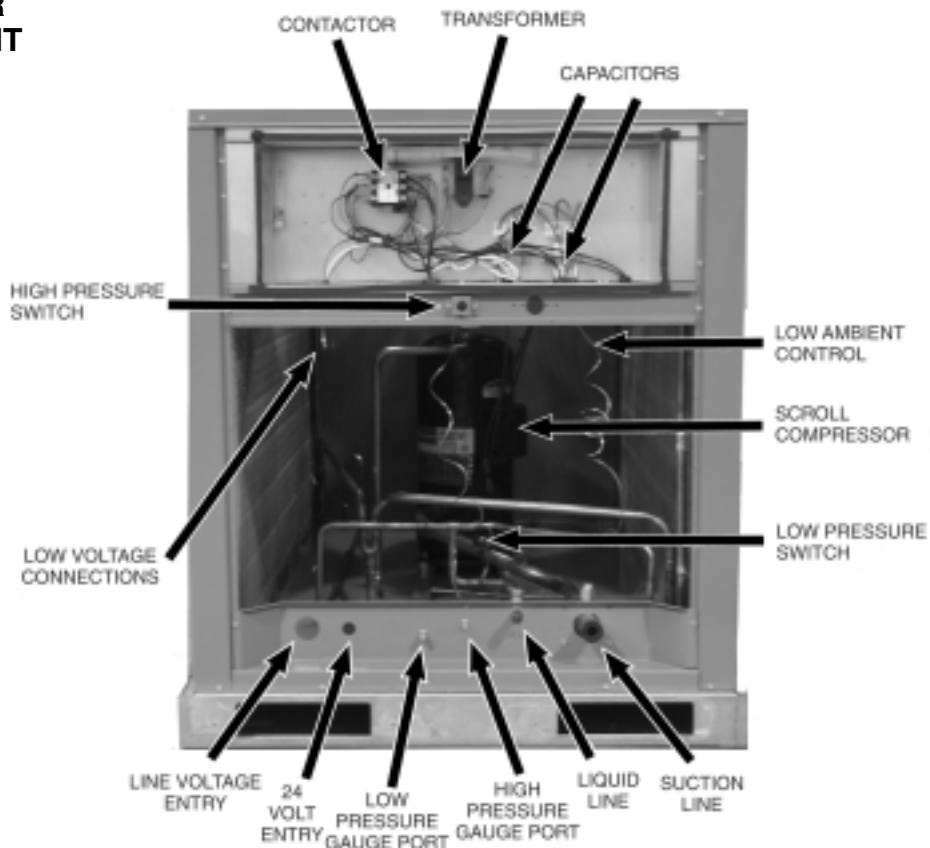

## CONTROL BOX

RAWL  
(-125, -150, -180 & -240)  
SHOWN, OTHER TANDEM  
COMPRESSOR MODELS  
TYPICAL

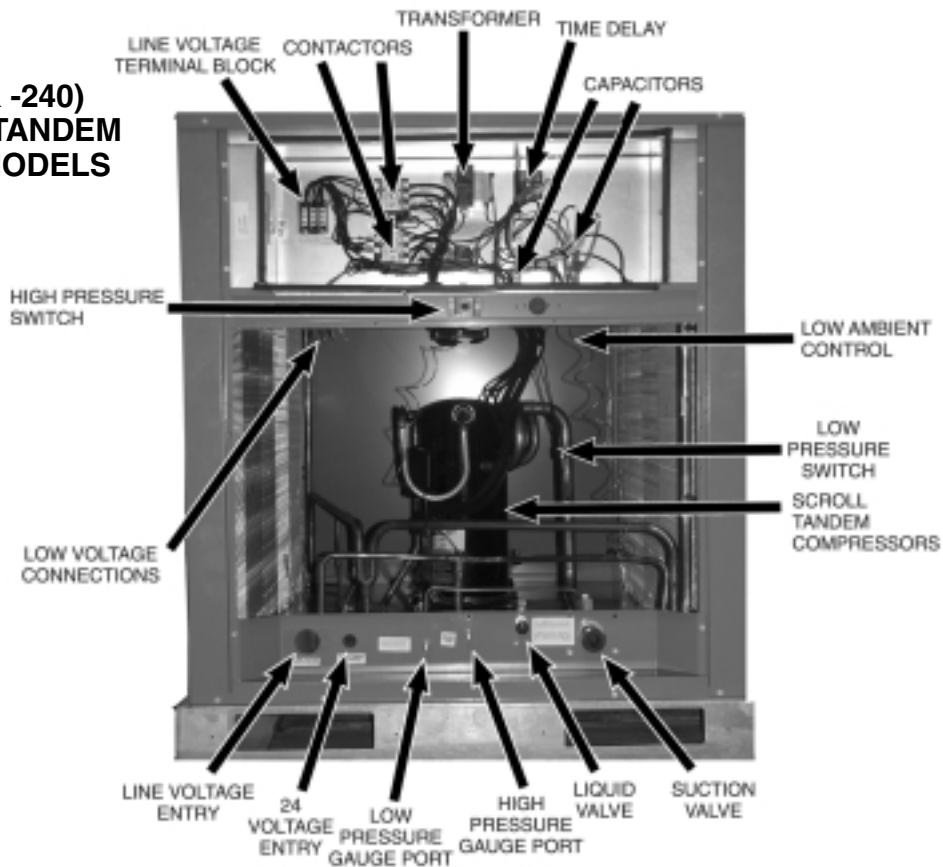

## CONDENSING UNIT—GROSS CAPACITY AND POWER (cont.)

<b>RAWL-180</b>						
<b>°F [°C] OUTDOOR AMBIENT TEMPERATURE</b>	<b>SATURATED EVAPORATOR TEMPERATURE °F [°C]</b>					
	<b>40 [4.4]</b>		<b>45 [7.2]</b>		<b>50 [10.0]</b>	
	<b>MBH [kW]</b>	<b>KW</b>	<b>MBH [kW]</b>	<b>KW</b>	<b>MBH [kW]</b>	<b>KW</b>
75 [24]	200.8 [58.84]	11.4	216.3 [63.38]	11.8	222.7 [65.24]	12.2
80 [27]	194.3 [56.94]	12.2	209.8 [61.47]	12.6	217.8 [63.82]	12.9
85 [29]	187.8 [55.03]	13.0	203.3 [59.56]	13.3	213.0 [62.40]	13.7
90 [32]	181.3 [53.12]	13.8	196.7 [57.64]	14.1	208.1 [60.98]	14.5
95 [35]	174.8 [51.22]	14.5	190.2 [55.73]	14.8	203.3 [59.56]	15.2
100 [38]	168.3 [49.31]	15.3	183.7 [53.82]	15.6	198.4 [58.14]	16.0
105 [41]	161.8 [47.40]	16.1	177.1 [51.90]	16.3	193.6 [56.72]	16.7
110 [43]	155.3 [45.50]	16.9	170.6 [49.99]	17.1	188.7 [55.30]	17.5
115 [46]	148.8 [43.59]	17.6	164.1 [48.08]	17.8	183.9 [53.88]	18.2

<b>RAWL-240</b>						
<b>°F [°C] OUTDOOR AMBIENT TEMPERATURE</b>	<b>SATURATED EVAPORATOR TEMPERATURE °F [°C]</b>					
	<b>40 [4.4]</b>		<b>45 [7.2]</b>		<b>50 [10.0]</b>	
	<b>MBH [kW]</b>	<b>KW</b>	<b>MBH [kW]</b>	<b>KW</b>	<b>MBH [kW]</b>	<b>KW</b>
75 [24]	272.7 [79.90]	17.6	294.3 [86.23]	18.0	316.7 [92.79]	18.5
80 [27]	264.1 [77.39]	18.5	285.6 [83.67]	18.9	307.7 [90.14]	19.4
85 [29]	255.6 [74.88]	19.4	276.9 [81.12]	19.9	298.6 [87.50]	20.3
90 [32]	247.0 [72.37]	20.4	268.1 [78.56]	20.8	289.6 [84.86]	21.3
95 [35]	238.5 [69.87]	21.3	259.4 [76.01]	21.7	280.6 [82.22]	22.2
100 [38]	229.9 [67.36]	22.2	250.7 [73.45]	22.6	271.6 [79.58]	23.1
105 [41]	221.3 [64.85]	23.1	242.0 [70.89]	23.5	262.6 [76.94]	24.1
110 [43]	212.8 [62.35]	24.0	233.2 [68.34]	24.4	253.6 [74.29]	25.0
115 [46]	204.2 [59.84]	24.9	224.5 [65.78]	25.3	244.5 [71.65]	25.9

KW — Condensing Unit Power (Compressor + Fan)

MBH—Gross Capacity x 1000 BTUH [kW]

NOTES: 1. All values at approximately 20°F [11.1°C] subcooling

2. Data includes 25 feet [7.62 m] of recommended vapor and liquid lines

[ ] Designates Metric Conversions

# UNIT DIMENSIONS AND WEIGHTS

MODEL	TOTAL WEIGHT LBS. [kg]	Corner Weights, Lbs. [kg]			
		A	B	C	D
RAWL-120	501 [227]	123 [56]	132 [60]	119 [54]	127 [58]
RAWL-125	586 [266]	144 [65]	154 [70]	139 [63]	149 [67]
RAWL-150	650 [295]	160 [72]	171 [78]	154 [70]	165 [75]
RAWL-180	746 [338]	183 [83]	196 [89]	177 [80]	189 [86]
RAWL-240	952 [432]	234 [106]	251 [114]	226 [103]	241 [110]

## 10 TON [35.2 kW]

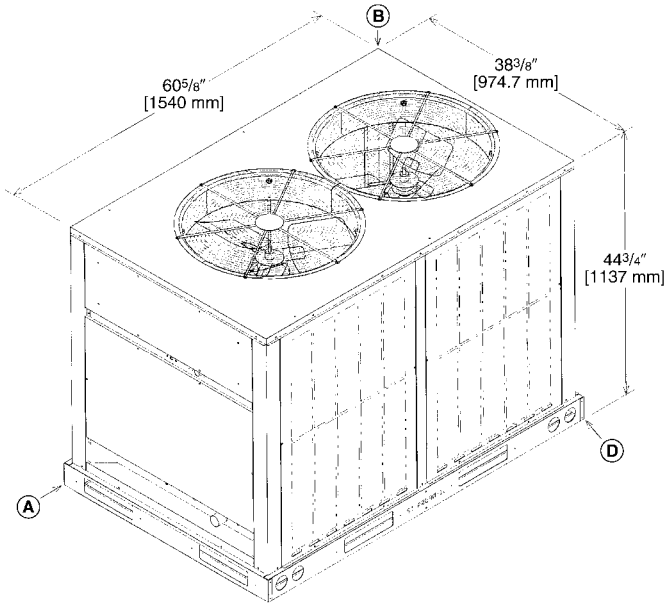

## BOTTOM VIEW

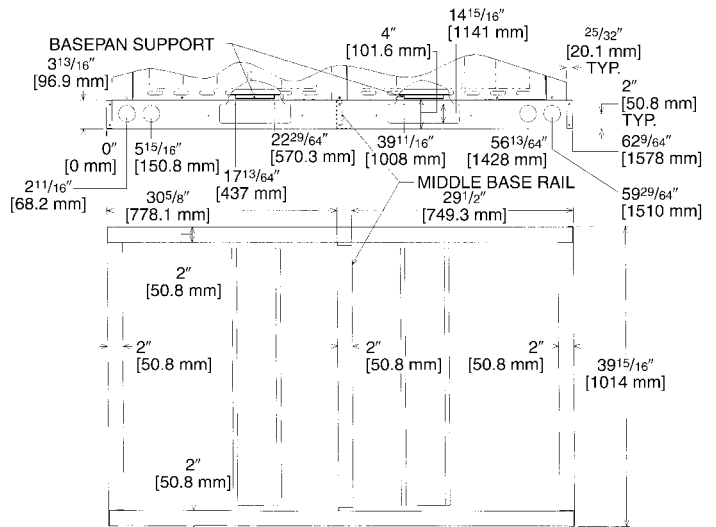

## 12.5 TON [44 kW]

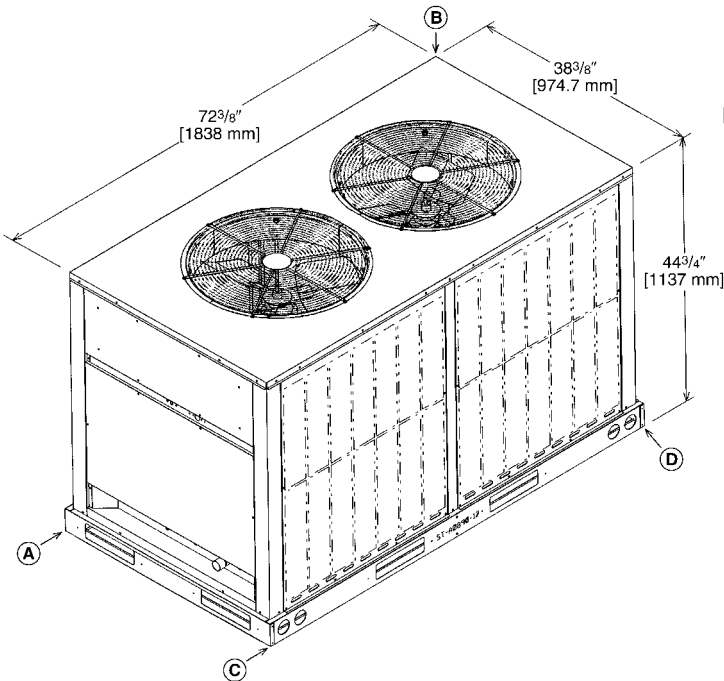

## BOTTOM VIEW

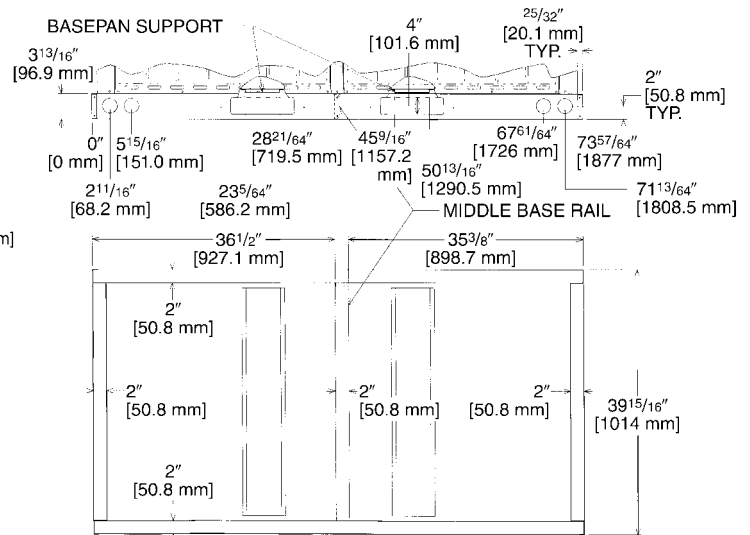

# UNIT DIMENSIONS (cont.)

## 15 TON & 20 TON [52.8 kW & 70.3 kW]

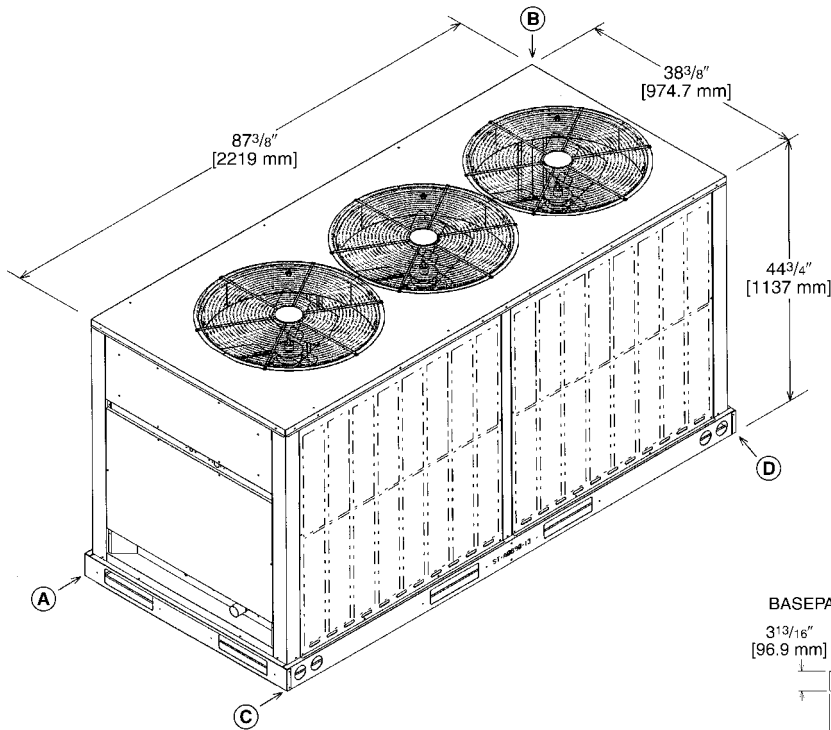

### BOTTOM VIEW

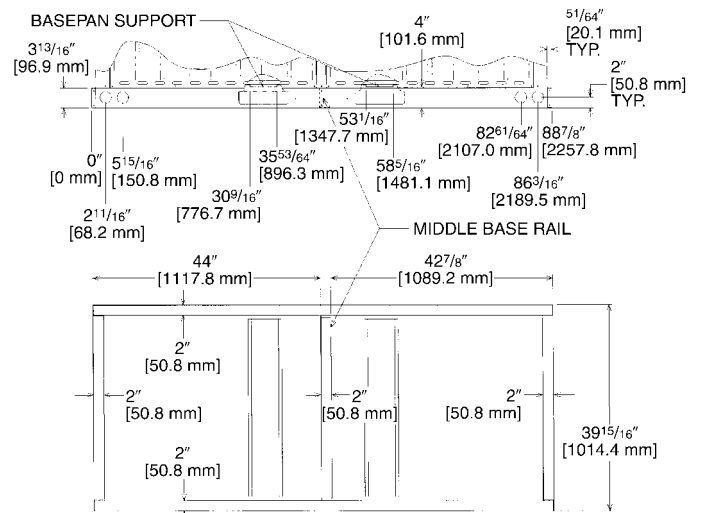

### CONTROL ACCESS SIDE VIEW

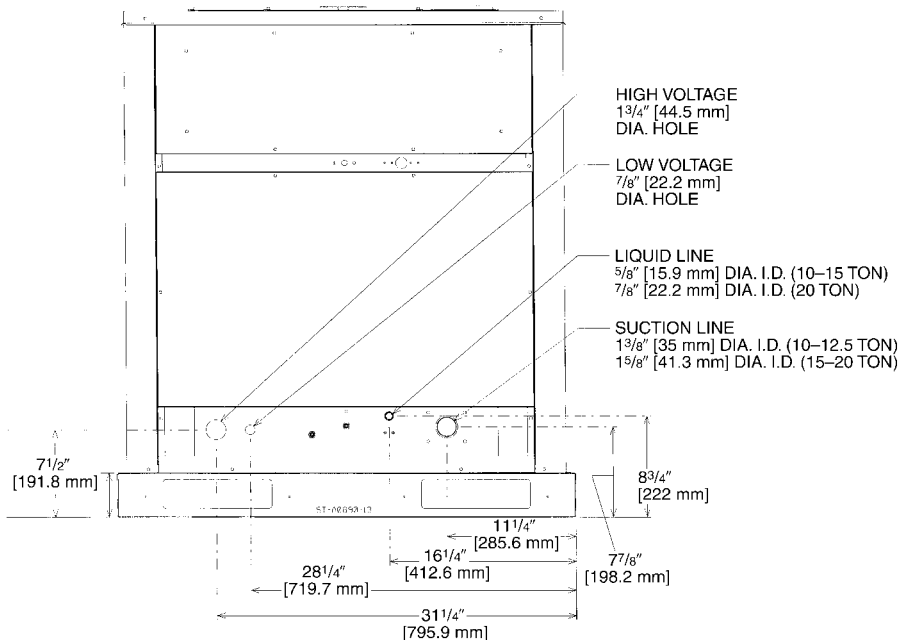

### ALL MODELS

# PERFORMANCE DATA @ AHRI STANDARD CONDITIONS—COOLING: RAWL-

MODEL NUMBERS		80°F [26.5°C] DB/67°F [19.5°C] WB INDOOR AIR 95°F [35°C] DB OUTDOOR AIR					SOUND RATING dB	INDOOR CFM [L/s]
OUTDOOR UNIT RAWL-	INDOOR COIL AND/OR AIR HANDLER	TOTAL CAPACITY BTU/H [kW]	NET SENSIBLE BTU/H [kW]	NET LATENT BTU/H [kW]	EER	IPLV		
Rev. 8/14/2008 120CAZ	RHGL-120Z ①	117,000 [34.3]	86,500 [25.3]	30,500 [8.9]	11.20	N/A	88	3,800 [1793]
	RCCL-D5013	118,000 [34.6]	86,500 [25.3]	31,500 [9.2]	11.20	N/A	88	3,800 [1793]
120DAZ	RHGL-120Z	117,000 [34.3]	86,500 [25.3]	30,500 [8.9]	11.20	N/A	88	3,800 [1793]
	RCCL-D5013	118,000 [34.6]	86,500 [25.3]	31,500 [9.2]	11.20	N/A	88	3,800 [1793]
120YAZ	RHGL-120Y	117,000 [34.3]	86,500 [25.3]	30,500 [8.9]	11.20	N/A	88	3,800 [1793]
	RCCL-D5013	118,000 [34.6]	86,500 [25.3]	31,500 [9.2]	11.20	N/A	88	3,800 [1793]
125CAZ	RHGL-120Z ①	116,000 [34.0]	87,000 [25.5]	29,000 [8.5]	11.20	14	88	3,800 [1793]
	RCCL-D5013	116,000 [34.0]	85,000 [24.9]	31,000 [9.1]	11.20	14	88	3,800 [1793]
125DAZ	RHGL-120Z	116,000 [34.0]	87,000 [25.5]	29,000 [8.5]	11.20	14	88	3,800 [1793]
	RCCL-D5013	116,000 [34.0]	85,000 [24.9]	31,000 [9.1]	11.20	14	88	3,800 [1793]
125YAZ	RHGL-120Y	116,000 [34.0]	87,000 [25.5]	29,000 [8.5]	11.20	14	88	3,800 [1793]
	RCCL-D5013	116,000 [34.0]	85,000 [24.9]	31,000 [9.1]	11.20	14	88	3,800 [1793]
150CAZ	RHGL-180Z ①	146,000 [42.8]	112,000 [32.8]	34,000 [10.0]	11.10	15	88	5,000 [2360]
150DAZ	RHGL-180Z	146,000 [42.8]	112,000 [32.8]	34,000 [10.0]	11.10	15	88	5,000 [2360]
150YAZ	RHGL-180Y	146,000 [42.8]	112,000 [32.8]	34,000 [10.0]	11.10	15	88	5,000 [2360]
180CAZ	RHGL-180Z ①	178,000 [52.2]	125,000 [36.6]	53,000 [15.5]	11.00	12.3	88	5,100 [2407]
180DAZ	RHGL-180Z	178,000 [52.2]	125,000 [36.6]	53,000 [15.5]	11.00	12.3	88	5,100 [2407]
180YAZ	RHGL-180Y	178,000 [52.2]	125,000 [36.6]	53,000 [15.5]	11.00	12.3	88	5,100 [2407]
240CAZ	RHGL-240Z ①	244,000 [71.5]	169,000 [49.5]	75,000 [22.0]	10.00	13.7	88	6,900 [3256]
240DAZ	RHGL-240Z	244,000 [71.5]	169,000 [49.5]	75,000 [22.0]	10.00	13.7	88	6,900 [3256]
240YAZ	RHGL-240Y	244,000 [71.5]	169,000 [49.5]	75,000 [22.0]	10.00	13.7	88	6,900 [3256]

① Highest sales volume tested combination required by D.O.E. test procedures.

N/A = Not applicable

[ ] Designates Metric Conversions



# ELECTRICAL & PHYSICAL DATA: RAWL-

Model No. RAWL-	ELECTRICAL										PHYSICAL				
	Phase Frequency (Hz) Voltage (Volts)	Compressor		Full Load Amperes (FLA)	Minimum Circuit Ampacity Amperes	Fuse or HACR Circuit Breaker		Outdoor Coil			Refrig. Per Circuit Oz. [g]	Weight			
		Rated Load Amperes (RLA)	Locked Rotor Amperes (LRA)			Fan Motor	Minimum Amperes	Maximum Amperes	Face Area Sq. Ft. [Sq. m]	No. Rows		CFM [L/s]	Net Lbs. [kg]	Ship Lbs. [kg]	
Rev. 8/14/2008															
120CAZ	3-60-208/230	30.1/30.1	225	4.8	43/43	50/50	60/60	27.00 [2.51]	2	8000 [3775]	339 [961.1]	501 [227.3]	541 [245.4]		
120DAZ	3-60-460	16.7	114	2.8	24	30	40	27.00 [2.51]	2	8000 [3775]	339 [961.1]	501 [227.3]	541 [245.4]		
120YAZ	3-60-575	12.2	80	2	18	25	25	27.00 [2.51]	2	8000 [3775]	339 [961.1]	501 [227.3]	541 [245.4]		
125CAZ	3-60-208/230	17.6/17.6	123	4.8	45/45	50/50	60/60	27.00 [2.51]	2	8000 [3775]	300 [8505]	586 [265.8]	626 [284.0]		
125DAZ	3-60-460	9.6	62	2.8	25	30	30	27.00 [2.51]	2	8000 [3775]	300 [8505]	586 [265.8]	626 [284.0]		
125YAZ	3-60-575	6.1	40	2	16	20	20	27.00 [2.51]	2	8000 [3775]	300 [8505]	586 [265.8]	626 [284.0]		
150CAZ	3-60-208/230	22.4/22.4	149	4.8	56/56	70/70	70/70	32.88 [3.05]	2	8000 [3775]	378 [10716]	650 [294.8]	690 [313.0]		
150DAZ	3-60-460	10.6	75	2.8	27	30	35	32.88 [3.05]	2	8000 [3775]	378 [10716]	650 [294.8]	690 [313.0]		
150YAZ	3-60-575	7.7	54	2	20	25	25	32.88 [3.05]	2	8000 [3775]	378 [10716]	650 [294.8]	690 [313.0]		
180CAZ	3-60-208/230	25/25	164	7.2	64/64	70/70	80/80	40.38 [3.75]	2	12000 [5663]	506 [14345]	746 [338.4]	786 [356.5]		
180DAZ	3-60-460	12.2	100	4.2	32	35	40	40.38 [3.75]	2	12000 [5663]	506 [14345]	746 [338.4]	786 [356.5]		
180YAZ	3-60-575	9	78	3	24	30	30	40.38 [3.75]	2	12000 [5663]	506 [14345]	746 [338.4]	786 [356.5]		
240CAZ	3-60-208/230	33.3/33.3	239	7.2	83/83	100/100	110/110	40.38 [3.75]	3	12000 [5663]	655 [18569]	952 [431.8]	992 [450.0]		
240DAZ	3-60-460	17.9	125	3.3	44	50	60	40.38 [3.75]	3	12000 [5663]	655 [18569]	952 [431.8]	992 [450.0]		
240YAZ	3-60-575	12.8	80	2.4	32	35	40	40.38 [3.75]	3	12000 [5663]	655 [18569]	952 [431.8]	992 [450.0]		

[ ] Designates Metric Conversions

## SEQUENCE OF OPERATION RAWL-120, Single Stage

1. When the room thermostat is set on “Cool”, “Fan Auto”, and the temperature is higher than the thermostat setting, the thermostat “Y1” circuit closes and energizes the compressor contactor (CC) through the closed contacts of the high pressure and low pressure controls. Power to the crankcase heater (CCH) will be de-energized by the auxiliary contacts (AUX-1)
2. Simultaneously, the “G” circuit provides power to the indoor blower motor circuit and starts indoor air circulation through the evaporator coil.
3. When the discharge pressure increases to 450 psig, the contacts on the low ambient control (LAC) will allow supply power to start the outdoor fan motors (ODF) which begin to pull air through the condenser coils.
4. The system will continue cooling operation, as long as the room thermostat “Y1” circuit and all safety device contacts are closed. The low ambient control (LAC) will open and close, allowing the outdoor fans to maintain discharge pressure between 250 and 450 psig.
5. When the thermostat is satisfied, the “Y1” circuit will open and de-energize the compressor contactor (CC), stopping compressor operation and closing the auxiliary contacts (AUX-1), which energizes the crankcase heater (CCH).
6. The thermostat “G” circuit will stop blower operation.

## SEQUENCE OF OPERATION RAWL-125, 150, 180, 240, Two Stage

1. When the room thermostat is set on “Cool”, “Fan Auto”, and the temperature is higher than the thermostat setting, the thermostat “Y1” circuit closes and energizes the number one compressor contactor (CC1) through the closed cooling relay (R) contacts. Power to the crankcase heater (CCH1) will be de-energized by the auxiliary contacts (AUX-1).
2. Simultaneously, the “G” circuit provides power to the indoor blower motor circuit and starts indoor air circulation through the evaporator coil.
3. When the discharge pressure increases to 450 psig, the contacts on the low ambient control (LAC) will allow supply power to start the outdoor fan motors (ODF) which begin to pull air through the condenser coils. The system is now in first stage cooling, operating at near fifty percent of full load capacity.
4. If the temperature at the thermostat continues to increase, the thermostat “Y2” circuit closes and after a 30 second delay, power passes through the time delay control (TDC) and energizes the number two compressor contactor (CC2) through the second set of closed cooling relay (R) contacts. Power to the crankcase heater (CCH2) will be de-energized by the auxiliary contacts (AUX-2)
5. The system will continue cooling at maximum capacity, as long as the room thermostat is demanding full load and all safety device contacts are closed. The low ambient control (LAC) will open and close, allowing the outdoor fans to maintain discharge pressure between 250 and 450 psig.
6. As the temperature at the thermostat drops enough to satisfy “Y2”, the circuit will open and de-energize the compressor contactor (CC2), stopping compressor operation and closing the auxiliary contacts (AUX-2), which energizes the crankcase heater (CCH2).
5. When continued cooling satisfies the “Y1” circuit, it will open and de-energize the compressor contactor (CC1), stopping compressor operation and closing the auxiliary contacts (AUX-1), which energizes the crankcase heater (CCH1).
6. The thermostat “G” circuit will stop blower operation.

[ ] Designates Metric Conversions