

Date: \_\_\_\_\_ For:  File  Resubmit  
 PO No.: \_\_\_\_\_  Approval  Other \_\_\_\_\_  
 Architect: \_\_\_\_\_ GC: \_\_\_\_\_  
 Engr: \_\_\_\_\_ Mech: \_\_\_\_\_  
 Rep: \_\_\_\_\_  
 (Company) \_\_\_\_\_ (Project Manager) \_\_\_\_\_

**LS300HLV**  
 Single Zone Extended Pipe  
 Outdoor Unit (ODU) - LSU300HLV Indoor Unit (IDU) - LSN300HLV



**Performance:**

**Cooling:**

Capacity (Min-Rated-Max, Btu/h)	3,070-30,000-34,000
SEER	18.5
EER	10.0

SEER - Seasonal Energy Efficiency Ratio EER - Energy Efficiency Ratio

**Heating:**

Capacity (Min-Rated-Max, Btu/h)	3,070-32,000-38,898
HSPF	10

HSPF - Heating Seasonal Performance Factor

Cooling Nominal Test Conditions: Indoor: 80°F DB/67°F WB Outdoor: 95°F DB/75°F WB  
 Heating Nominal Test Conditions: Indoor: 70°F DB/60°F WB Outdoor: 47°F DB/43°F WB

**Electrical:**

Power Supply (V <sup>1</sup> /Hz/Ø)	208-230/60/1
-------------------------------------	--------------

**Outdoor Unit:**

MOP (A)	35
MCA (A)	23
Cooling Rated Amps (A)	17.55
Heating Rated Amps (A)	17.55
Compressor (A)	17.3
Fan Motor (A)	0.25

MOP - Maximum Overcurrent Protection MCA - Minimum Circuit Ampacity

**Total Power Input:**

Cooling Power Input (kW)	3.0
Heating Power Input (kW)	3.1

**Piping:**

Liquid Line (in, OD)	3/8
Vapor Line (in, OD)	5/8
Additional Refrigerant (oz/ft)	0.38
Max Pipe Length (ft) <sup>2</sup>	164
Piping Length (no add'l refrigerant, ft)	24.6
Max Elevation (ft)	98.4

**Controls Features:**

- 24-Hour on/off timer
- 4-Way auto swing
- Auto changeover
- Auto restart
- Built-in low ambient standard, down to 14°F (cooling mode)
- Chaos wind
- Inverter (variable speed compressor)
- Jet cool/Jet heat
- 3M HAF Filter
- Sleep mode
- Condensate Sensor Connection
- Cooling only function

**Included Accessories:**

- Wireless Handheld Controller - AKB74055401

**Optional Accessories (sold separately):**

- LG Programmable Thermostat - PREMTB10U
- Low Ambient Wind Baffle (Cooling operation to 0°F) - ZLABGP02A

For a complete list of available accessories, contact your LG representative.

For continual product development, LG reserves the right to change specifications without notice.

© LG Electronics U.S.A., Inc., Englewood Cliffs, NJ. All rights reserved. "LG Life's Good" is a registered trademark of LG Corp. /www.lghvac.com

**Operating Range:**

**Outdoor Unit:**

Cooling (°F DB)	14-118
Heating (°F WB)	-4-65

**Indoor Unit:**

Cooling (°F WB)	53-75
Heating (°F DB)	60-86

**Unit Data:**

Refrigerant Type	R410A
Refrigerant Control	EEV
Refrigerant Charge (lbs)	4.85
ODU Sound Pressure (±3 dB(A)) <sup>3</sup>	55
IDU Sound Pressure (H/M/L) (±3 dB(A)) <sup>3</sup>	49/44/40
ODU Net Unit Weight (lbs)	125
ODU Shipping Weight (lbs)	133
IDU Net Unit Weight (lbs)	40
IDU Shipping Weight (lbs)	46
Heat Exchanger Coating	GoldFin™

**Fan:**

ODU Type	Propeller
IDU Type	Cross Flow
Fan Speeds (Fan/Cooling/Heating)	5/6/6
Quantity (ODU + IDU)	1 + 1
Motor/Drive	Brushless Digitally Controlled/Direct
ODU Max Air Flow Rate (CFM)	2,119
IDU Air Flow H/M/L (CFM)	706/530/459
Dehumidification (pts/hr)	5.9

**Notes:**

1. Acceptable operating voltage: 187V-253V.
2. Piping lengths are equivalent.
3. Sound Pressure levels are tested in an anechoic chamber under ISO Standard 1996.
4. All communication/power cable to be minimum 18 AWG, 4-conductor, stranded, shielded and must comply with applicable local and national code.
5. See Engineering Manual for sensible and latent capacities.
6. Power wiring cable size must comply with the applicable local and national code.
7. The indoor unit comes with a dry helium charge.
8. This data is rated 0 ft above sea level, with 24.6 ft of refrigerant line and a 0 ft level difference between outdoor and indoor units.
9. Must follow installation instructions in the applicable LG installation manual.



**Outdoor Unit (ODU) - LSU300HLV**  
Single Zone Extended Pipe



Tag #:

Date:

PO No.:

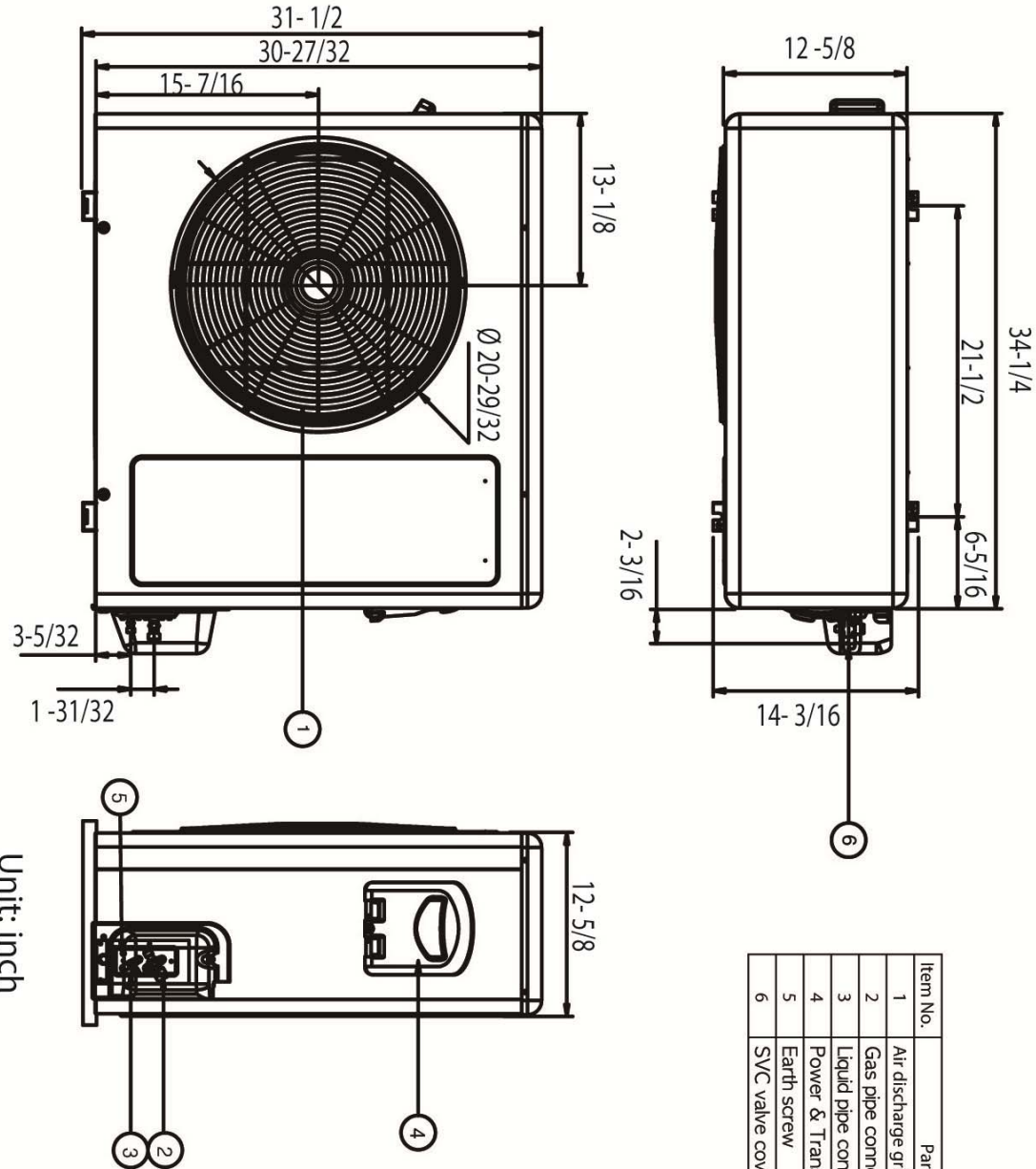

Unit: inch

Item No.	Part Name	Remarks
1	Air discharge grille	
2	Gas pipe connection	
3	Liquid pipe connection	
4	Power & Transmission connection	
5	Earth screw	
6	SVC valve cover	

# Indoor Unit (IDU) - LSN300HLV

## Single Zone Extended Pipe



Tag #:

Date:

PO No.:

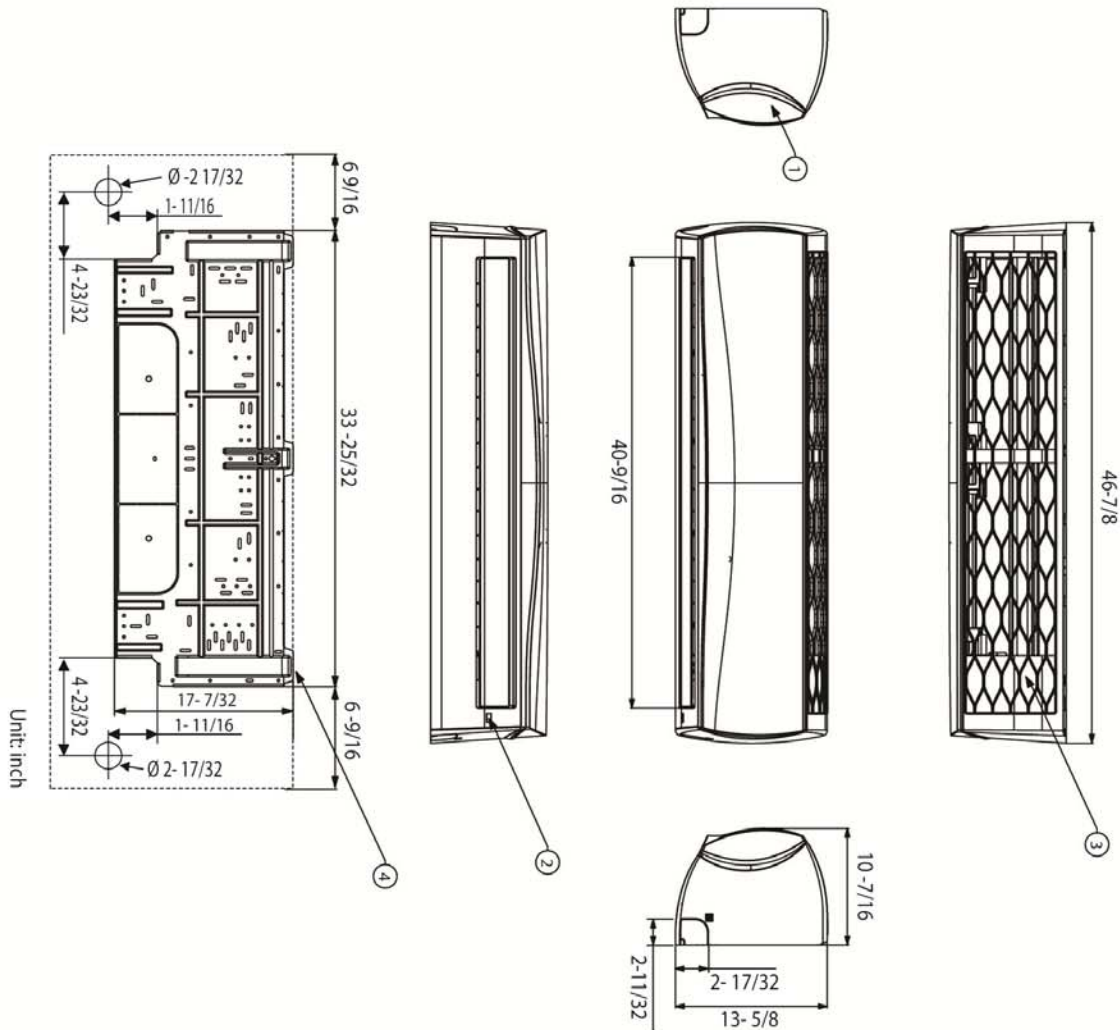

Item No.	Part Name	Remarks
1	Front Panel	
2	Display & Signal Receiver	
3	Air Suction Grille	
4	Installation Plate	