

Model: \_\_\_\_\_ Item #: \_\_\_\_\_ Date: \_\_\_\_\_

Project: \_\_\_\_\_ Qty: \_\_\_\_\_ Approved By: \_\_\_\_\_

## Model 17-109WL

8" Center Wall Mount Pre-Rinse w/ Wall Bracket and Add-On Faucet, 12" Spout

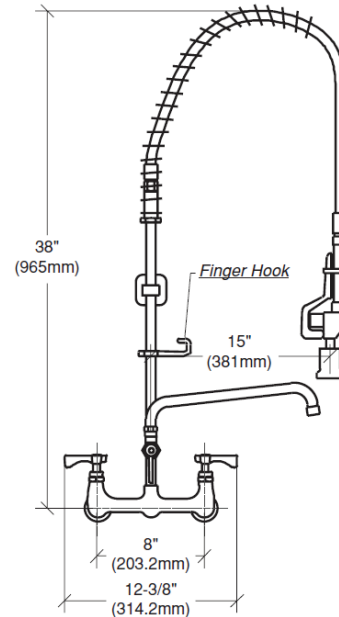

Front View

### Standard Features

- Pre-assembled to cut installation time
- Interchangeable with most brands
- 1/4 Turn High Performance Ceramic Cartridge Valves
- 1.2 GPM @ 60 PSI Spray Head, 1.8 GPM faucet spout
- Built-In Check Valves
- Solid chrome plated brass base
- Built for high volume and durability
- Full Replacement Parts Available
- 1 Year Warranty

### Specifications

- 8" Center Wall Mount
- Wall Bracket with mounting kit
- 38" high with 15" overhang
- 44" stainless steel hose with grip, tested to 400 PSI
- 1/2" NPT Female Inlets
- Add-On Faucet with 12" Spout
- Temperature range of 40° to 180°
- Mounting kit included
  - (1/2" NPT x 1-1/2" male nipples with locknuts)
- Riser Pipe with Hook: 3/8" NPT x 18"
- Low Lead Compliant
- Shipping Weight: 15 lbs.
- Case Quantity: 3

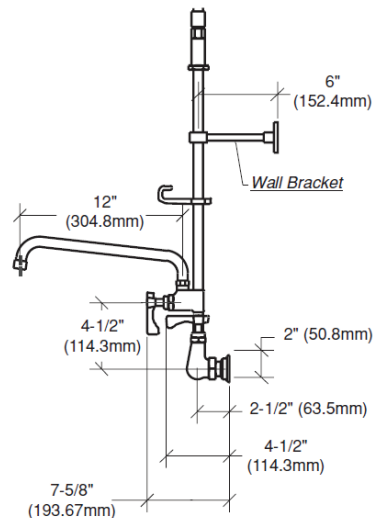

Side View