



P70, P72, and P170 Series Controls for Low Pressure Applications

Description

The P70, P72, and P170 Controls for low pressure applications are designed primarily for low pressure cut-out control, pump-down control, and capacity control on commercial refrigeration and air conditioning applications.

These controls are available in several pressure ranges and are compatible with most common refrigerants. They may also be used on other non-corrosive fluid applications. Ammonia-compatible models are also available.

Controls also are available in several different electrical ratings and switch configurations. The P72 models provide direct control of 208 to 240 volt single-phase motors up to 3 horsepower, and 208 to 220 volt three-phase motors up to 5 horsepower.

Refer to the *P70, P72, and P170 Series Controls for Low Pressure Applications Product Bulletin (Part No. 24-7664-2608)* for important product application information.

Features

- all-steel case and cover built to provide long lasting, rugged protection for internal components
- sight-set calibrated pressure adjustment displays a visible pressure scale, fully adjustable through the range without removing the cover (on NEMA 1 enclosure models)

- MICRO-SET™ differential option allows for precise control on critical low pressure applications
- manual reset lockout option provides trip-free low pressure lockout that cannot be overridden or reset until pressure returns to specified level
- limited knob adjustment option restricts control adjustment ranges and deters tampering and over-adjustment

Applications

NEMA 1 enclosures are standard on most models.

- **P70A and P170A models** with single-pole, single-throw (SPST) Open Low switch action are the most popular models, and are typically used for low pressure cut-out and pump-down control.
- **P70 and P170 models** are also available with SPST Open High switch action, and are typically used for capacity control. Models with single-pole, double-throw (SPDT) or four-wire, two-circuit switch action allow users to install alarm devices or other control circuits.
- **P72 models** have a double-pole, single-throw (DPST) switch with load-carrying contacts that can provide direct control of 208 to 240 V single-phase motors up to 3 horsepower, and 208 to 220 V 3-phase motors up to 5 horsepower. See the DPST Electrical Ratings (P72A, B, C, and D Models) that follow.



**P70AB-12 MICRO-SET
Low Pressure Control**

Repair Information

If the P70, P72, and P170 Series Controls for Low Pressure Applications fail to operate within their specifications, replace the units. For a replacement control, contact the nearest Johnson Controls® representative.



P70, P72, and P170 Series Controls for Low Pressure Applications (Continued)

Selection Chart for Standard P70, P72, and P170 Controls for Low Pressure Applications

Product Code Number	Switch Action	Range psi (kPa)	Differential psi (kPa)	Pressure Connection	Max. Overpressure	Max. Working Pressure	Limited Knob Adjustment
MICRO-SET Controls (For Non-Corrosive Refrigerants)							
P70AB-12C	SPST open low	12 in. Hg to 80 (-41 to 551)	Minimum 5 (34) Maximum 35 (241)	36 in. capillary with 1/4 in. flare nut	525 psig (3,617 kPa)	80 psig (551 kPa)	Supplied, but not assembled
P170AB-12C				1/4 in. external flare connector			
P70EA-14C	SPDT 1 to 3 open low			36 in. capillary with 1/4 in. flare nut			
P170EA-14C	1 to 2 close low			1/4 in. external flare connector			
All-Range Controls (For Non-Corrosive Refrigerants)							
P70AB-1C	SPST open low	20 in. Hg to 100 (-68 to 690)	Minimum 7 (48) Maximum 50 (345)	1/4 in. external flare connector	325 psig (2,239 kPa)	100 psig (690 kPa)	Supplied, but not assembled
P70AB-2C				36 in. capillary with 1/4 in. flare nut			
P70BA-1C			Manual reset lockout	1/4 in. external flare connector			None
P70BA-10C							
P70EA-10C	SPDT 1 to 3 open low 1 to 2 close low		5 (34) fixed				
P72AA-1C	DPST open low		Minimum 7 (48) Maximum 50 (345)	36 in. capillary with 1/4 in. flare nut			Mounted on differential screw
P72AB-1C							
P170AB-2C	SPST open low			1/4 in. external flare connector			None
P70CA-1C	SPST open high			36 in. capillary with 1/4 in. flare nut			
P170CA-1C				1/4 in. external flare connector			
All-Range Controls (Ammonia-Compatible)							
P70AA-5C	SPST open low	20 in. Hg to 100 (-68 to 690)	Minimum 7 (48) Maximum 50 (345)	1/4 in. SS Internal NPT	325 psig (2,239 kPa)	100 psig (690 kPa)	None
P70CA-4C	SPST open high						
P70GA-11C	Four-wire, Two-circuit						
P70HA-3C	Line M1 close low Line M2 open low						

Note: To order models not listed in the selection chart, please contact Johnson Controls/PENN® Refrigeration Application Engineering at 1-800-275-5676.

Technical Specifications

Single Pressure Controls Switch Action, Low Event, High Event, and Models

Switch and Action	Low Event	High Event	Models
SPST Open Low	Cut-Out (Opens Line to M1)	Cut-In (Closes Line to M1)	P70A, P70B, P170A
SPST Open High	Cut-In (Closes Line to M1)	Cut-Out (Opens Line to M1)	P70C, P70D, P170C, P170D
SPDT	Opens 1 to 2 and closes 1 to 3	Closes 1 to 2 and Opens 1 to 3	P70E, P70F
Four-Wire, Two-Circuits, 1 N.O., 1 N.C. Open Low	Cut-Out (Opens M2 to Line and Closes M1 to Line)	Cut-In (Closes M2 to Line and Opens M1 to Line)	P70G, P70H
Four-Wire, Two-Circuits, 1 N.O., 1 N.C. Open High	Cut-In (Closes M2 to Line and Opens M1 to Line)	Cut-Out (Opens M2 to Line and Closes M1 to Line)	P70J, P70K, P170K
DPST Open Low	Cut-Out (Opens M1 to Line and M2 to Line)	Cut-In (Closes M1 to Line and M2 to Line)	P72A, P72B
DPST Open High	Cut-In (Closes M1 to Line and M2 to Line)	Cut-Out (Opens M1 to Line and M2 to Line)	P72C, P72D

P70, P72, and P170 Series Controls for Low Pressure Applications (Continued)

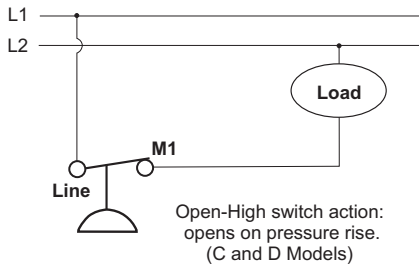
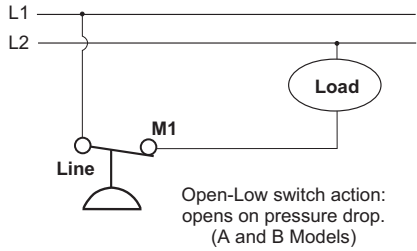

p7s_wir_spst.eps

**Typical Wiring for SPST Open Low Switch and Open High Switch
(P70A, B, C, D, and P170A, C, D, Models)**

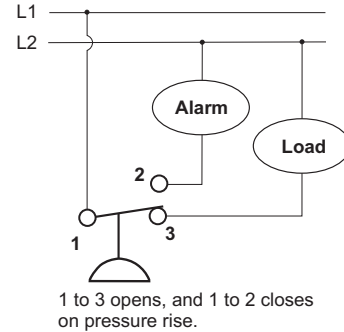

p7s_wir_spdt.eps

Typical Wiring for SPDT Switch (P70E, F Models)

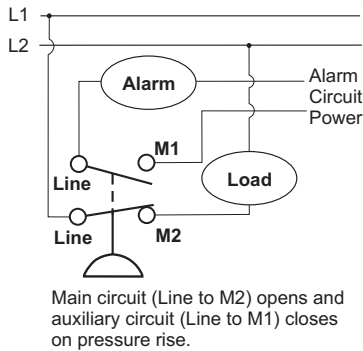

**Typical Wiring for Four-Wire Two-Circuit Switch
(P70G and H Models)**

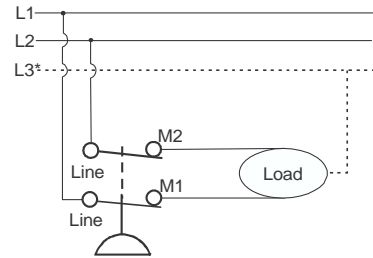

*(L3 is third supply line in three-phase applications.)

p7s_wir_dpst.eps

Typical Wiring for DPST Switch (P72A and B Models)



P70, P72, and P170 Series Controls for Low Pressure Applications (Continued)

Technical Specifications (Continued)

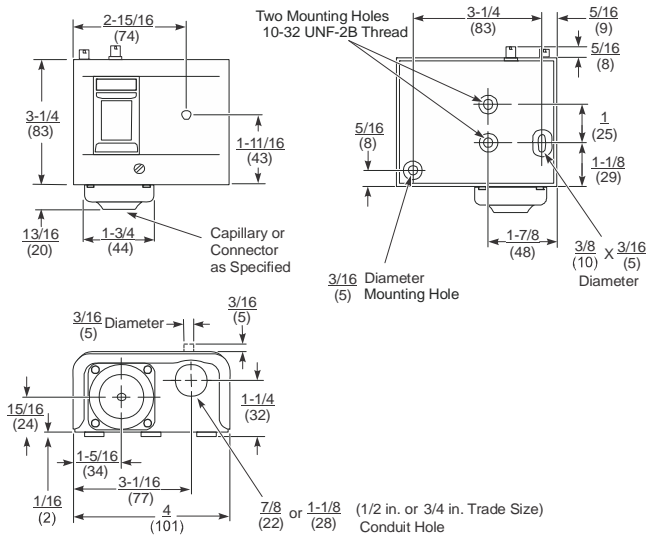

p70_low_NEMA1_dims.eps

Dimensions for Low Pressure Controls with NEMA 1 Enclosure, in. (mm)*

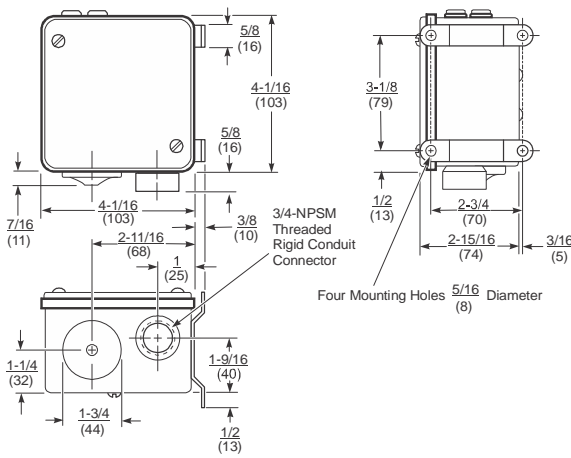

p70_low_NEMA3R_dims.eps

Dimensions for Low Pressure Controls with NEMA 3R Enclosure, in. (mm)*

* These dimensions are nominal and are subject to accepted manufacturing tolerances and application variables.

DPST Electrical Ratings (P72A, B, C, and D Models)

	Standard Ratings					Hermetic Compressor Ratings	
	120 VAC, Single-Phase	208 VAC, Single-Phase	240 VAC, Single-Phase	208 VAC, Three-Phase	220 VAC, Three-Phase	208 VAC, Single-Phase	240 VAC, Single-Phase
Motor Horsepower	2	3	3	5	5	--	--
Motor Full-Load A	24	18.7	17	15.9	15	24	24
Motor Locked-Rotor A	144	112.2	102	95.4	90	144	144
AC Non-Inductive A	24	24	24	24	24	--	--
DC Non-Inductive A	3	0.5	0.5	0.5	0.5	--	--
Pilot Duty	125 VA at 120 to 600 VAC; 57.5 VA at 120 to 300 VDC						

SPST Electrical Ratings (P70A, B, C, and D, and P170A, C, and D Models)

	Single-Phase Ratings			
	Standard			Hermetic Compressor
	120 VAC	208 VAC	240 VAC	208/240 VAC
Motor Horsepower	2	3	3	--
Motor Full-Load A	24	18.7	17	20
Motor Locked-Rotor A	144	112.2	102	120
Non-Inductive A	22	22	22	--
Pilot Duty	125 VA, 120 to 600 VA; 57.5 VA, 120 to 300 VDC			

SPDT Electrical Ratings 1hp Switch (P70E Models)

	Standard Single-Phase Ratings			
	120 VAC	208 VAC	240 VAC	277 VAC ¹
Motor Full Load A	16.0	9.2	8.0	7.0
Motor Locked Rotor A	96.0	55.2	48.0	42.0
Non-Inductive A	16.0	9.2	8.0	-
Pilot Duty	125 VA at 120 to 600 VAC		125 VA at 24 to 600 VAC	

1. Rating for P70EC models only

SPDT Electrical Ratings 1/4 hp Switch (P70F Models)

	Standard Single-Phase Ratings		
	120 VAC	208 VAC	240 VAC
Motor Full Load A	6.0	3.3	3.0
Motor Locked Rotor A	36.0	19.8	18.0
Non-Inductive A	6.0	6.0	6.0
Pilot Duty	125 VA at 24 to 240 VAC		

Four-Wire, Two-Circuit Electrical Ratings (P70G, H, J, and K, and P170K Models)

	Standard Single-Phase Ratings							
	Line-M2 (Main Contacts)				Line-M1 (Auxiliary Contacts)			
	120 VAC	208 VAC	240 VAC	277 VAC	120 VAC	208 VAC	240 VAC	277 VAC
Motor Full Load A	16.0	9.2	8.0	--	6.0	3.3	3.0	--
Motor Locked Rotor A	96.0	55.2	48.0	--	36.0	19.8	18.0	--
Non-Inductive A	16.0	9.2	8.0	7.2	6.0	6.0	6.0	6.0
Pilot Duty for both sets of contacts	125 VA at 24 to 600 VAC; 57.5 VA at 120 to 300 VDC							

The performance specifications are nominal and conform to acceptable industry standards. For applications at conditions beyond these specifications, consult the local Johnson Controls office. Johnson Controls, Inc. shall not be liable for damages resulting from misapplication or misuse of its products. © 2015 Johnson Controls, Inc. www.johnsoncontrols.com