



# SERVICE PARTS LIST

**BULLETIN NO.**  
**54-26-2770**

SPECIFY CATALOG NO. AND SERIAL NO. WHEN ORDERING PARTS		REVISED BULLETIN	DATE
<b>M18™ FUEL™ 1/2" Square Impact Wrench (Baseline)</b>			Nov. 2017
<b>CATALOG NO.</b>	<b>2755-20</b>	<b>STARTING SERIAL NO.</b>	<b>G78A</b>
			<b>WIRING INSTRUCTION</b> <b>SEE PAGE 2</b>

**EXAMPLE:**  
00 0 Component Parts (Small #) Are Included  
When Ordering The Assembly (Large #).

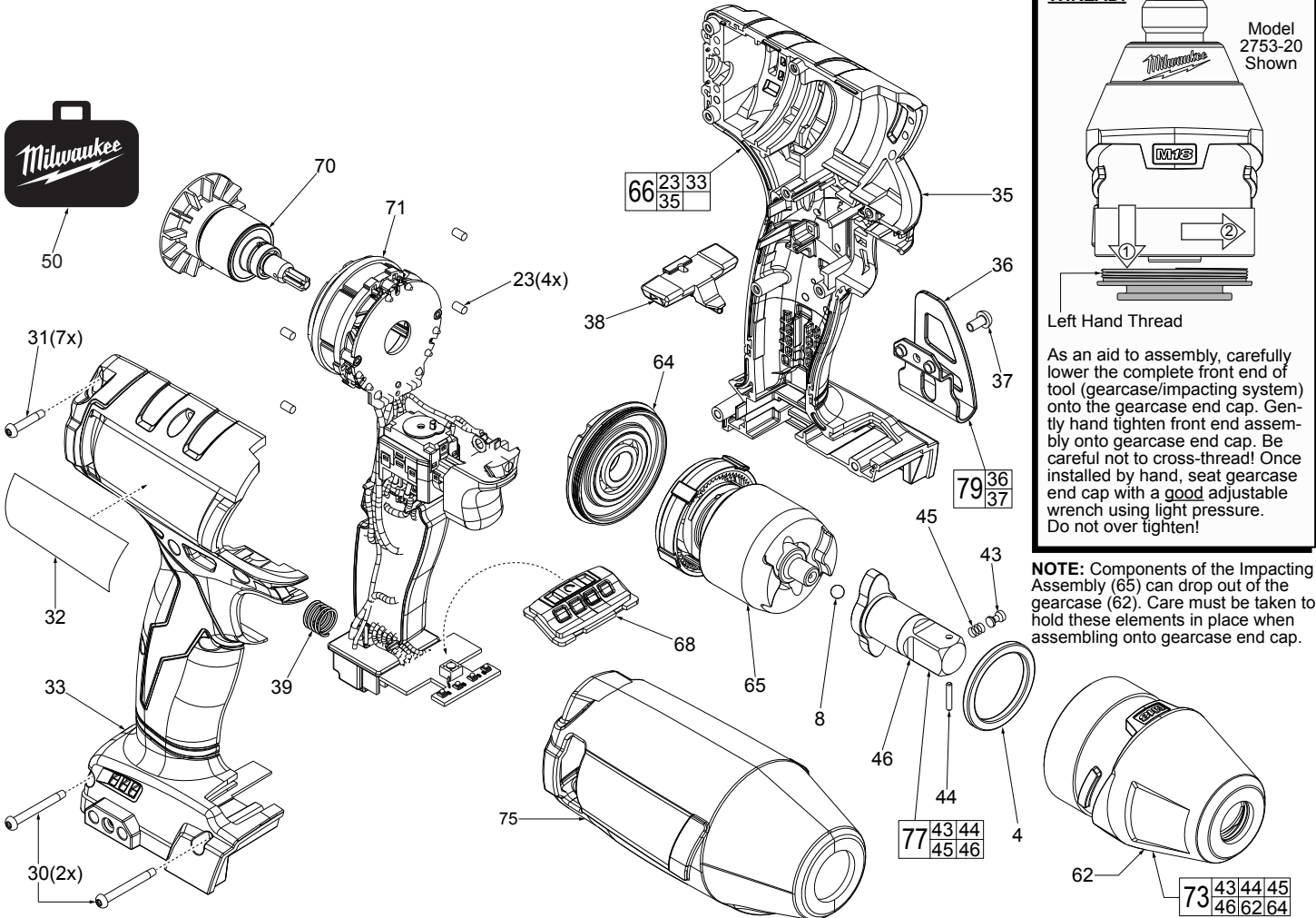

**IMPORTANT NOTE: Gearcase end cap #64 is LEFT HAND THREAD!**

Model 2753-20 Shown

Left Hand Thread

As an aid to assembly, carefully lower the complete front end of tool (gearcase/impacting system) onto the gearcase end cap. Gently hand tighten front end assembly onto gearcase end cap. Be careful not to cross-thread! Once installed by hand, seat gearcase end cap with a good adjustable wrench using light pressure. Do not over tighten!

**NOTE:** Components of the Impacting Assembly (65) can drop out of the gearcase (62). Care must be taken to hold these elements in place when assembling onto gearcase end cap.

FIG.	PART NO.	DESCRIPTION OF PART	NO. REQ.
4	45-88-2653	Plastic Washer	(1)
8	02-02-1300	5.0mm Steel Ball	(1)
23	45-30-2653	Rubber Slug	(4)
30	06-82-0013	M3 x 38mm Pan Hd. ST TP T-10 Screw	(2)
31	06-82-7326	M3 x 16mm Pan Hd. ST TP T-10 Screw	(7)
32	12-20-0046	Service Nameplate	(1)
33	-----	Housing Halve - Right	(1)
35	-----	Housing Halve - Left	(1)
36	-----	Belt Clip	(1)
37	06-82-0130	6-32 x 5/16" Pan Hd. T-15 Screw	(1)
38	45-24-0013	Forward / Reverse Shuttle	(1)
39	40-50-1090	Spring	(1)
43	44-60-0014	Detent Pin	(1)
44	44-60-0022	Pivot Pin	(1)
45	40-50-0925	Detent Spring	(1)
46	-----	1/2" Square Anvil	(1)
50	42-55-2754	Blow Molded Carrying Case	(1)
62	28-50-0012	Gearcase with Bushing	(1)
64	44-66-0028	Gearcase End Cap with Ball Bearing	(1)
65	14-46-0016	Impacting Assembly	(1)
66	31-44-0033	Housing Assembly	(1)
68	45-24-0044	Speed Selector Assembly	(1)
70	16-07-2754	Rotor Assembly	(1)
71	14-20-0016	Electronics Assembly	(1)
73	14-30-0013	Gearcase / Anvil Assembly	(1)
75	49-12-0012	Rubber Boot (Optional, Accessory)	(1)
77	42-06-0018	1/2" Square Anvil Assembly	(1)
79	42-70-0059	Belt Clip Assembly	(1)

FIG.	LUBRICATION
	<b>(Type 'J' Grease, No. 49-08-4220):</b>
62	Coat inside of bushing inside front gearcase (62) with grease.
65	Lightly coat the I.D. of the ring gear and the center of the planet gears of impacting assembly (65) with grease.
70	Coat pinion of rotor assembly (70) with grease.

Rotor Assembly

Stator Assembly with Hall PCBA

Watch for pinched wires here. Tuck leads down in cavity behind switch.

Battery Connector Block Assembly

Compression Spring

High Voltage Protection Wire. Place terminal over screw boss and route down in cavity behind forward/reverse shuttle.

Route LED wires down in cavity behind forward/reverse shuttle.

LED Assembly

On-Off Switch

Main PCBA

Speed PCBA

Speed Selector Assembly

