

Available Finishes / Materials:  
VG -- Phoenix Vanguard  
Standard Finish: VG

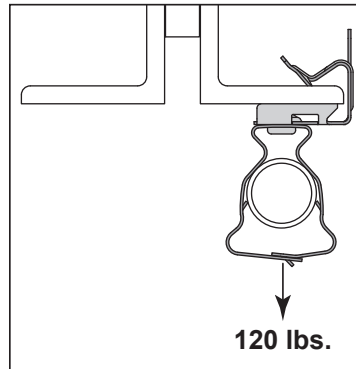
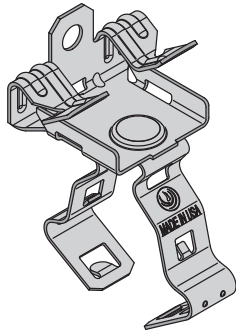

- Supports pipe and conduit from beam flanges.
- Conduit clip rotates 360 degrees.
- Flange thickness range stamped on part.
- Only a hammer required for installation.
- **Material:** Spring Steel
- **Finish:** Vanguard

Catalog No.	Min. - Max. Flange Thickness	Conduit Size	Box Qty
F2-4 C8-12	1/8" - 1/4"	1/2" & 3/4" EMT, Rigid	50
F5-8 C8-12	5/16" - 1/2"	1/2" & 3/4" EMT, Rigid	50
F9-12 C8-12	9/16" - 3/4"	1/2" & 3/4" EMT, Rigid	50
F2-4 C16	1/8" - 1/4"	1" EMT, Rigid	50
F5-8 C16	5/16" - 1/2"	1" EMT, Rigid	50
F9-12 C16	9/16" - 3/4"	1" EMT, Rigid	50
F2-4 C20	1/8" - 1/4"	1-1/4" EMT, Rigid	50
F5-8 C20	5/16" - 1/2"	1-1/4" EMT, Rigid	50
F9-12 C20	9/16" - 3/4"	1-1/4" EMT, Rigid	25
F2-4 C24	1/8" - 1/4"	1-1/2" EMT, Rigid	50
F5-8 C24	5/16" - 1/2"	1-1/2" EMT, Rigid	50
F9-12 C24	9/16" - 3/4"	1-1/2" EMT, Rigid	25
F2-4 C32	1/8" - 1/4"	2" EMT, Rigid	25
F5-8 C32	5/16" - 1/2"	2" EMT, Rigid	25
F9-12 C32	9/16" - 3/4"	2" EMT, Rigid	25

## Material Specifications and Finishes

### Spring Steel:

Cold Roll, ASTM A684 Grade 1055 Spring Steel

### VG – Phoenix Vanguard

Phoenix Vanguard coating is a multi-step process that meets the 1000 hour salt spray test per ASTM B117 and DIN 50021. **Vanguard coating is WEEE, ELV and RoHS compliant.** VG Finish is approved for wet and dry applications. It is a chrome free three step coating system that combines an inorganic zinc-rich basecoat with an aluminum-rich organic topcoat.

Note: Specifications subject to change without notice.

<b>Project:</b>	<b>Date:</b>	<b>Phone:</b>
<b>Submitted By:</b>	<b>Address:</b>	
<b>Comment</b>		