

Available Finishes / Materials:

PG -- Pre-Galvanized zinc

Standard Finish: PG

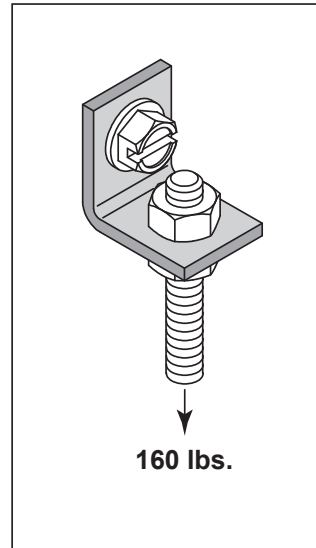
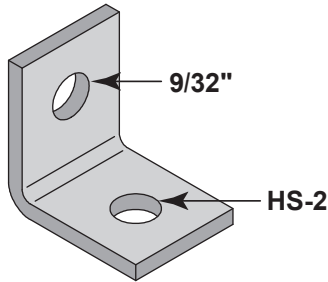

- Accepts wire, chain and rod drops from concrete or wood.
- **Material:** Steel
- **Finish:** Pre-Galvanized

| Catalog No. | HS - 2 | Box Qty |
|-------------|--------|---------|
| AB4 | 9/32" | 100 |
| AB6 | 13/32" | 100 |

Material Specifications and Finishes

Carbon Steel – ASTM A1011-00 SS GR 33 or ASTM A1011-00CS Type B

PG – ASTM A653 G-90 Pre-galvanized zinc is produced by continuously rolling steel coils or sheets through molten zinc at the mills. The coils or sheets are slit to size and fabricated by forming, shearing or punching to produce the finished product. During fabrication cut edges are not generally zinc coated; however, the zinc near the uncoated metal becomes a sacrificial anode to protect the bare areas.

Note: Specifications subject to change without notice.

| | | |
|----------------------|-----------------|---------------|
| Project: | Date: | Phone: |
| Submitted By: | Address: | |
| Comment | | |