

SUBMITTAL INFORMATION

Mechanical Joint Retainer (*UFR1500-CA-x-U style*)

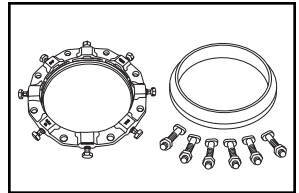

4" - 12" SERIES UFR1500 MECHANICAL JOINT RESTRAINT FOR C900, C909 PVC OR HDPE PACKAGED WITH ACCESSORIES

Ductile iron actuating screw, with the Auto-Tork break-away head design, ensures proper torque during installation

Safety stop ensures ring segments can never be over-tightened

Mechanical joint gasket

Auto-Tork Bolt

Restraint Segment

Bolt Hole Cross Section

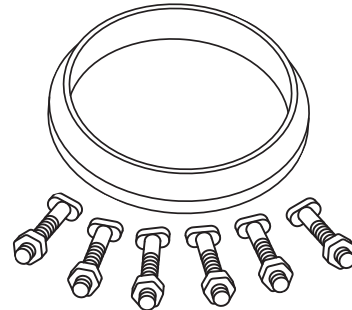
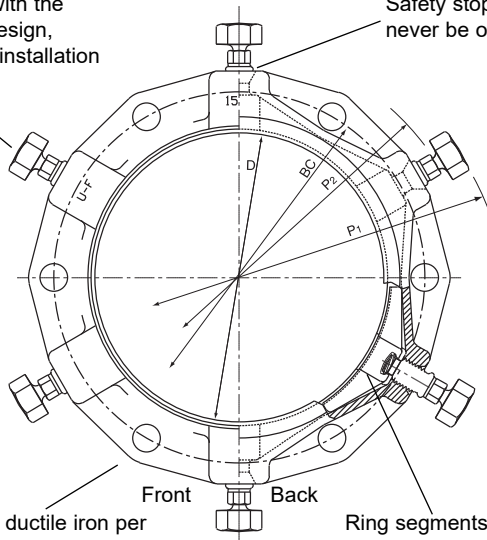

High strength, low alloy t-bolts & nuts (AWWA C111)

Gland body is of high strength ductile iron per ASTM A536, grade 65-45-12. Compatible with all mechanical joints conforming to ANSI / AWWA C111 / A21.11

Ring segments are ductile iron per ASTM A536 and heat treated to a hardness of 370 BHN minimum

NOM PIPE SIZE	PIPE O.D.	CATALOG NUMBER	NO. OF SEGMENTS	APPROX. WEIGHT (LBS)	P1*	P2**	BC	D	PRESSURE RATING				✓ SUBMITTED ITEM(S)
									C900			C909	
									DR-14	DR-18	DR-25	PC-235	
4"	4.80	UFR1500-CA-4-U	4	14.2	13.00"	9.40"	7.50"	4.90"	305	235	165	235	
6"	6.90	UFR1500-CA-6-U	6	20.1	15.13"	11.60"	9.50"	7.00"	305	235	165	235	
8"	9.05	UFR1500-CA-8-U	6	24.3	17.25"	13.75"	11.75"	9.15"	305	235	165	235	
10"	11.10	UFR1500-CA-10-U	8	33.0	19.38"	16.00"	14.00"	11.20"	305	235	165	235	
12"	13.20	UFR1500-CA-12-U	8	37.3	21.50"	18.05"	16.25"	13.30"	305	235	165	235	

*Maximum O.D. of gland on pipe before Auto-Tork heads are removed (as shipped)

**Maximum O.D. of gland on pipe after Auto-Tork heads are removed

Note: Ford recommends the use of a properly sized insert stiffener when using UFR1500 on HDPE

FEATURES

- Fits C900, C909 and HDPE
- Full circle contact and support of the pipe wall
- "Auto-Tork" actuating screws with heads specially designed to twist off at the correct installation torque, leaving a hex head in case future system maintenance or removal is required
- Set of high strength, low alloy t-bolts and nuts (AWWA C111)
- Mechanical joint gasket (AWWA C111)
- Series 1500 eliminates the need to pour expensive and time consuming concrete thrust blocks
- Series 1500 UL/FM approved, 4"-12" nominal size C900 PVC, for use on listed and approved PVC pipe
- Restraining segments are mechanically retained in pockets
- Gland, screws and segments are protected with black Armorguard e-coat
- Gland colored red for identification purposes

The Ford Meter Box Company considers the information in this submittal form to be correct at the time of publication. Item and option availability, including specifications, are subject to change without notice. Please verify that your product information is current.



The Ford Meter Box Company, Inc.

P.O. Box 443, Wabash, Indiana U.S.A. 46992-0443

Phone: 260-563-3171 / Fax: 800-826-3487

Overseas Fax: 260-563-0167

www.fordmeterbox.com



08/17/17

Submitted By: