

## 300OS PERIMETER FLOOR REGISTER

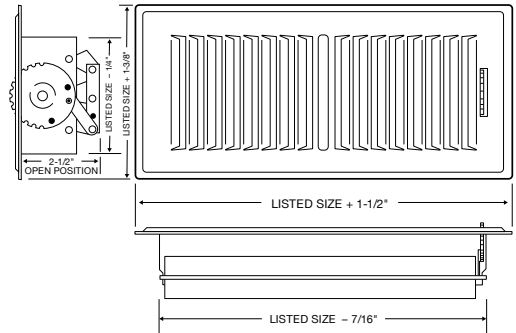

- Heavy-gauge stamped face
- One-piece, stamped, straight, hemmed lanced face
- Lances 9/16" on center
- 30° angle of deflection
- Foot-operated, multi-shutter air volume control
- Brown or Bright White enamel finish

Model	Material	Damper
300OS	Steel	MS



## 302A FLOOR DIFFUSER

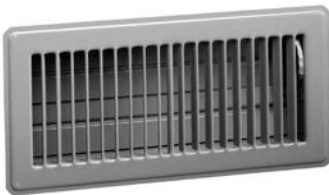

- Welded construction
- Foot-operated dial control
- Brown or Bright White enamel finish
- Multi-angle fin setting
- Rolled fin for strength and safety

Model	Material	Damper
302A	Steel	MS

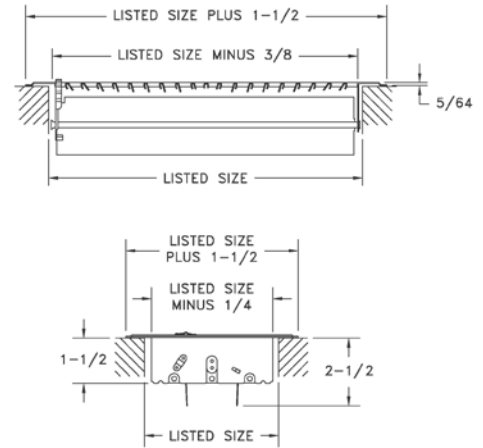

## 301 TOE SPACE GRILLE



- Heavy-gauge stamped face
- Multi-angle fins
- Brown or Bright White enamel finish

Model	Material	Damper
301	Steel	none

