



# REFRIGERATION

**PARAGON**

## Product Drawings

### 8045-00 and 8045-20

Electric Heat Defrosting

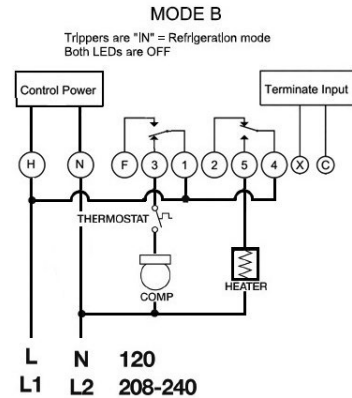
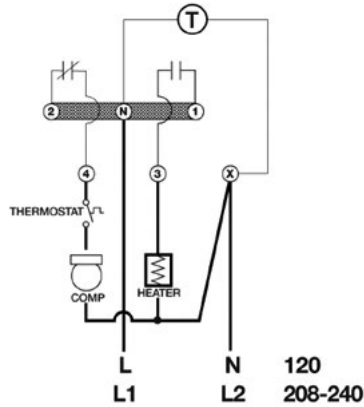

8145-AV	H (L/L1)	N (N/L2)	F	3 COMP	1 (L/L1)	2	5 HEATER	4 (L/L1)	X	C
8045-00	N (L/L1)	X (N/L2)		4	N (L/L1)		3	N (L/L1)		
8045-20										
DTAV40	1-N (L1)	X (L2)		4	1-N (L1)		3	2 (L1)		

### 8047-00 and 8047-20

Electric Heat Defrosting

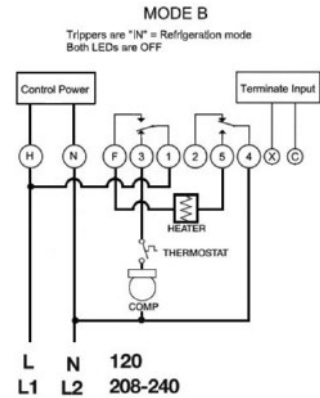
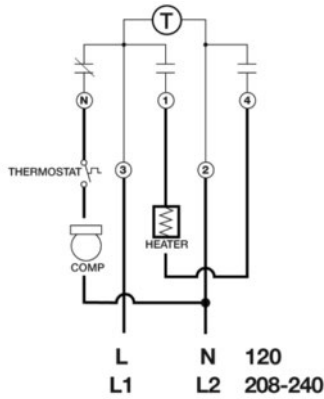

8145-AV	H (L/L1)	N (N/L2)	F	3 COMP	1 (L/L1)	2	5 HEATER	4 (N/L2)	X	C
8047-00	3 (L/L1)	2 (N/L2)	1 HEATER	N COMP	3 (L/L1)		4 HEATER	2 (N/L2)		
8047-20										
DTAV40	3 (L/L1)	2 (N/L2)	1 HEATER	N COMP	3 (L/L1)		4 HEATER	2 (N/L2)		



## Specifications

Part Numbers	Description	Switch Arrangement Contacts 2-4	Switch Arrangement Contacts 1-3	Switch Arrangement Contacts 3-N	Termination Type	Electrical Rating
8041-00	Electric Heat	Closed	Open	Closed	Time	120V AC 60 Hz
8045-00	Electric Heat, Hot Gas or Compressor Shutdown	Closed	Open	None	Time	120V AC 60 Hz
8045-20	Electric Heat, Hot Gas or Compressor Shutdown	Closed	Open	None	Time	208-240V AC 60 Hz
8045-21	Electric Heat, Hot Gas or Compressor Shutdown	Closed	Open	None	Time	208-240V AC 50 Hz
8141-00	Electric Heat, Hot Gas or Compressor Shutdown	Closed	Open	Closed	Temperature or Pressure	120V AC 60 Hz
8141-20	Electric Heat, Hot Gas or Compressor Shutdown	Closed	Open	Closed	Temperature or Pressure	208-240V AC 60 Hz
8145-00	Electric Heat, Hot Gas or Compressor Shutdown	Closed	Open	None	Temperature or Pressure	120V AC 60 Hz
8145-20	Electric Heat, Hot Gas or Compressor Shutdown	Closed	Open	None	Temperature or Pressure	208-240V AC 60 Hz
8145-20M	Electric Heat, Hot Gas or Compressor Shutdown	Closed	Open	None	Temperature or Pressure	208-240V AC 60 Hz
8145-21	Electric Heat, Hot Gas or Compressor Shutdown	Closed	Open	None	Temperature or Pressure	208-240V AC 50 Hz
8145-20B	Electric Heat, Hot Gas or Compressor Shutdown	Closed	Open	None	Temperature or Pressure	208-240V AC 60 Hz
8245-21	Electric Heat, Hot Gas or Compressor Shutdown	Closed	Open	None	Pressure	208-240V AC 50 Hz
8245-20	Electric Heat, Hot Gas or Compressor Shutdown	Closed	Open	None	Pressure	208-240V AC 60 Hz
D81-8145-00EX (ANZ, EU, MEX, SA)	Electric Heat, Hot Gas or Compressor Shutdown	Closed	Open	None	Temperature or Pressure	120V AC 60 Hz
D81-8145-20EX (ANZ, EU, MEX, SA)	Electric Heat, Hot Gas or Compressor Shutdown	Closed	Open	None	Temperature or Pressure	208-240V AC 60 Hz
D81-8145-21EX (ANZ, EU, MEX, SA)	Electric Heat, Hot Gas or Compressor Shutdown	Closed	Open	None	Temperature or Pressure	208-240V AC 50 Hz

## Product Drawings

### Electric Heat Defrosting

Models 8045-00 and 8045-20 -  
Wiring Diagram

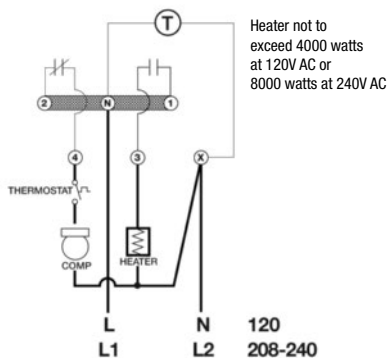

Models 8041-00 and 8041-20 -  
Wiring Diagram

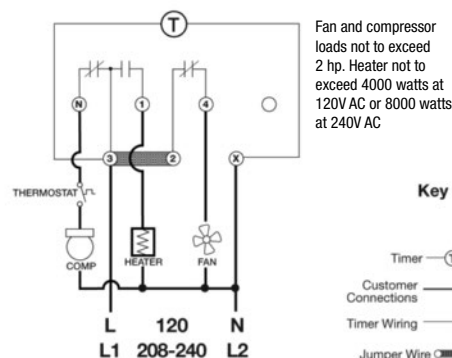

#### Key to Symbols

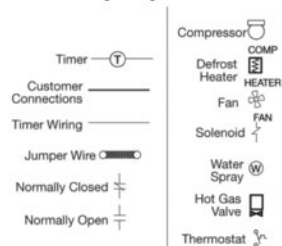

**1** Year Limited Warranty