

Ruud Achiever® Series Heat Pump



RP15 Series

Efficiencies: 14-15 SEER/11.5-12.5 EER
Nominal Sizes 1¹/₂ to 5 Ton [5.28 to 17.6 kW]
Cooling Capacities 17.3 to 60.5 kBTU
[5.7 to 17.7 kW]



"Proper sizing and installation of equipment is critical to achieve optimal performance. Split system air conditioners and heat pumps must be matched with appropriate coil components to meet Energy Star. Ask your Contractor for details or visit www.energystar.gov."

- New composite base pan – dampens sound, captures louver panels, eliminates corrosion and reduces number of fasteners needed
- Improved tubing design – reduces vibration and stress, making unit quieter and reducing opportunity for leaks
- Optimized defrost characteristics - decrease defrosting and provide better home comfort
- Powder coat paint system – for a long lasting professional finish
- Optimized reversing valve sizing – improves shifting performance for quieter unit operation and increased life of the system
- Enhanced mufflers – help to dissipate vibration energy for quieter unit operation
- Scroll compressor – a sound abating feature added to the compressor significantly reduces noise when system transitions in and out of defrost mode
- Modern cabinet aesthetics – increased curb appeal with visually appealing design
- Curved louver panels – provide ultimate coil protection, enhance cabinet strength, and increased cabinet rigidity
- Optimized fan orifice – optimizes airflow and reduces unit sound
- Rust resistant screws – confirmed through 1500-hour salt spray testing
- PlusOne™ **Expanded Valve Space** – 3"-4"-5" service valve space – provides a minimum working area of 27-square inches for easier access
- Integrated heat pump lift receptacle – allows standard CPVC stands to be inserted into the base
- PlusOne™ **Triple Service Access** – 15" wide, industry leading corner service access – makes repairs easier and faster. The two fastener removable corner allows optimal access to internal unit components. Individual louver panels come out once fastener is removed, for faster coil cleaning and easier cabinet reassembly
- Diagnostic service window with two-fastener opening – provides access to the TXV valves and the heat pump reversing valve before opening the unit.
- External gauge port access – allows easy connection of "low-loss" gauge ports
- Single-row condenser coil – makes unit lighter and allows thorough coil cleaning to maintain "out of the box" performance
- 35% fewer cabinet fasteners and fastener-free base – allow for faster access to internal components and hassle-free panel removal
- Service trays – hold fasteners or caps during service calls
- QR code – provides technical information on demand for faster service calls
- Fan motor harness with extra-long wires – allows unit top to be removed without disconnecting fan wire

TABLE OF CONTENTS

Standard Feature Table	3
Available SKUs	3
Features & Benefits	4-5
Model Number Identification	6-7
Physical Data	8
Electrical Data	8
Accessories	9
Weighted Sound Power	9
Thermostats.....	9
Unit Dimensions.....	10
Clearances.....	11
Wiring Diagrams	12
Application Guidelines.....	12
Refrigerant Line Size Information.....	13-16
Performance Data	17-37
Guide Specifications	38
Limited Warranty	39

Standard Feature Table

Feature	18	24	30	36	42	48	60
R-410a Refrigerant	√	√	√	√	√	√	√
Maximum SEER	15.0	15.0	15.0	15.0	15.0	15.0	15.0
Maximum EER	12.5	12.5	12.5	12.5	12.5	12.5	12.5
Scroll Compressor	√	√	√	√	√	√	√
Field Installed Filter Drier	√	√	√	√	√	√	√
Front Seating Service Valves	√	√	√	√	√	√	√
High Pressure Switch	√	√	√	√	√	√	√
Low Pressure Switch	√	√	√	√	√	√	√
Internal Pressure Relief Valve	√	√	√	√	√	√	√
Internal Thermal Overload	√	√	√	√	√	√	√
Long Line capability	√	√	√	√	√	√	√
Low Ambient capability with Kit	√	√	√	√	√	√	√
3-4-5 Service Valve Access	√	√	√	√	√	√	√
Composite Basepan	√	√	√	√	√	√	√
2 Screw Control Box Access	√	√	√	√	√	√	√
15" Access to Internal Components	√	√	√	√	√	√	√
Quick release louver panel design	√	√	√	√	√	√	√
No fasteners to remove along bottom	√	√	√	√	√	√	√
Optimized Venturi Airflow	√	√	√	√	√	√	√
Single row condenser coil	√	√	√	√	√	√	√
Powder coated paint	√	√	√	√	√	√	√
Rust resistant screws	√	√	√	√	√	√	√
QR code	√	√	√	√	√	√	√
External gauge ports	√	√	√	√	√	√	√
Service trays	√	√	√	√	√	√	√

√ = Standard

Available SKU

Available Models	Description
RP1518BJ1NA	<i>Achiever</i> ® 1 1/2 ton 15 SEER Single-Stage Heat Pump-208/230/1/60
RP1524BJ1NA	<i>Achiever</i> ® 2 ton 15 SEER Single-Stage Heat Pump-208/230/1/60
RP1530BJ1NA	<i>Achiever</i> ® 2 1/2 ton 15 SEER Single-Stage Heat Pump-208/230/1/60
RP1536AJ1NA	<i>Achiever</i> ® 3 ton 15 SEER Single-Stage Heat Pump-208/230/1/60
RP1542AJ1NA	<i>Achiever</i> ® 3 1/2 ton 15 SEER Single-Stage Heat Pump-208/230/1/60
RP1548AJ1NA	<i>Achiever</i> ® 4 ton 15 SEER Single-Stage Heat Pump-208/230/1/60
RP1560AJ1NA	<i>Achiever</i> ® 5 ton 15 SEER Single-Stage Heat Pump-208/230/1/60
RP1536AC1NA	<i>Achiever</i> ® 3 ton 15 SEER Single-Stage Heat Pump-208/230/3/60
RP1542AC1NA	<i>Achiever</i> ® 3 1/2 ton 15 SEER Single-Stage Heat Pump-208/230/3/60
RP1548AC1NA	<i>Achiever</i> ® 4 ton 15 SEER Single-Stage Heat Pump-208/230/3/60
RP1560AC1NA	<i>Achiever</i> ® 5 ton 15 SEER Single-Stage Heat Pump-208/230/3/60

Introduction to RP15 Heat Pump

The RP15 is our 15 SEER heat pump and is part of the Ruud heat pump product line that extends from 14 to 20 SEER. This highly featured and reliable heat pump is designed for years of reliable, efficient operation when matched with Ruud indoor aluminum evaporator coils and furnaces or air handler units with aluminum evaporators.

Our unique composite base (1) reduces sound emission, eliminates rattles, significantly reduces fasteners, eliminates corrosion and has integrated brass compressor attachment inserts (2). Furthermore it has incorporated into the design, water management features, means for hand placement (3) for unit maneuvering, screw trays (4) and inserts for lifting unit off pad. (5)

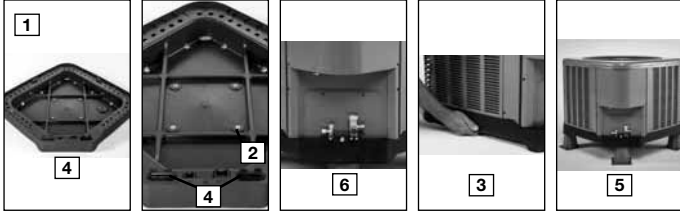

Service Valves (6) are rigidly mounted in the composite base with 3" between suction and discharge valves, 4" clearance below service valves and a minimum of 5" above the service valves, creating industry leading installation ease. The minimum 27-square inches around the service valves allows ample room to remove service valve schrader prior to brazing, plenty of clearance for easy brazing of the suction and discharge lines to service valve outlets, easy access and hookup of low loss refrigerant gauges (7), and access to the service valve caps for opening. For applications with long-line lengths up to 250 feet total equivalent length, up to 200 feet heat pump above evaporator, or up to 80 feet evaporator above heat pump, the long-line instructions in the installation manual should be followed.

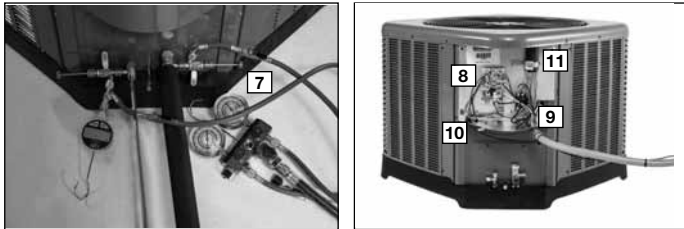

Controls are accessed from the corner of the unit by removing only two fasteners from the control access cover, revealing the industry's largest 15" wide and 14" tall control area (8). With all this room in the control area the high voltage electrical whip (9) can easily be inserted through the right size opening in the bottom of the control area. Routing it leads directly to contractor lugs for connection. The low voltage control wires (10) are easily connected to units low voltage wiring. If contactor, defrost control or capacitor (11) needs to be replaced there is more than adequate space to make the repair. Furthermore, the service window (12) can be removed to access the TXV and reversing valve by removing two screws or the entire corner can be removed providing ultimate access to the TXV or reversing valve. (13)

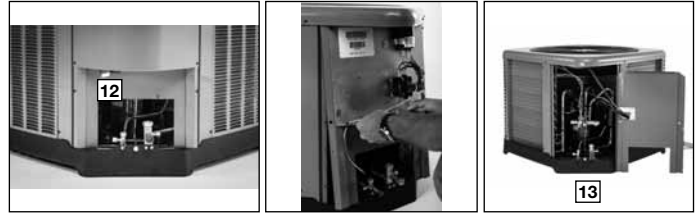

If in the rare event, greater access is needed to internal components, such as the compressor, the entire corner of the unit can be removed along with the top cover assembly to have unprecedented access to interior of the unit (14). Extra wire length is incorporated into each outdoor fan and compressor so top cover and control panel can be positioned next to unit. With minimal effort the plug panel can be removed from the compressor and the outdoor fan wires can be removed from the capacitor to allow even more uncluttered access to the interior of the unit (15). Outdoor coils heights range from as short as 25" to 45", aiding access to the compressor. Disassembly to this degree and complete reassembly only takes a first time service technician less than 10 minutes. (18)

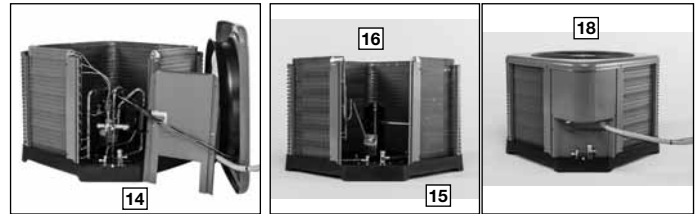

All units utilize strong formed louver panels which provide industry leading coil protection. Louver removal for coil cleaning is accomplished by removing one screw and lifting the panel out of the composite base pan (17). All RP15 units utilize single row coils (16) making cleaning easy and complete, restoring the performance of the heat pump back to out of the box performance levels year after year.



The outdoor fan motor has sleeve bearings and is inherently protected. The motor is totally enclosed for maximum protection from weather, dust and corrosion. Access to the outdoor fan is made by removing four fasteners from the fan grille. The outdoor fan can be removed from the fan grille by removing 4 fasteners in the rare case outdoor fan motor fails.

Each cabinet has optimized composite (19) fan orifice assuring efficient and quiet airflow.



The entire cabinet has powder post paint (20) achieving 1000 hour salt spray rating, allowing the cabinet to retain its aesthetics throughout its life.

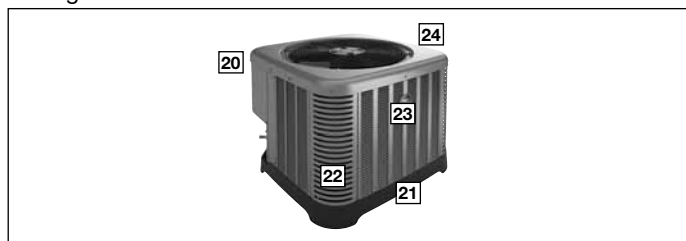

Scroll compressors with standard internal pressure relief and internal thermal overload are used on all capacities assuring longevity of high efficient and quiet operation for the life of the product. All RP15 Heat Pumps come standard with high and low pressure switches.

Each unit is shipped with filter drier for field installation and will trap any moisture or dirt that could contaminate the refrigerant system.



All cabinets have industry leading structural strength due to the composite base pan (21), interlocking corner post (22), formed curved louver panels (23) and drawn top cover (24) making it the most durable cabinet on the market today.

Each RP15 capacity has undergone rigorous psychrometric testing to assure performance ratings of capacity, SEER, EER and HSPF per AHRI Standard 210/240 rating conditions. Also each unit bears the UL mark and each unit is certified to UL 1995 safety standards.



Each unit has undergone specific strain and modal testing to assure tubing (25) is outside the units natural frequency and that the suction and discharge lines connected to the compressor withstand any starting, steady state operation or shut down forces imposed by the compressor.

All units have been sound tested in sound chamber to AHRI 270 rating conditions, and A-weighted Sound Power Level tables produced, assuring units have acceptable noise qualities (see page 9). Each unit has been ran in cooling operation at 95°F and 47°F and sound ratings for the RP15 range from as low as 73 dBA to 79 dBA.

All units have been ship tested to assure units meet stringent "over the road" shipping conditions.

As manufactured all units in the RP15 family have cooling capability to 55 °F. Addition of low ambient control will allow the unit to operate down to 0°F.

Factory testing is performed on each unit. All component parts meet well defined specification and continually go through receiving inspections. Each component installed on a unit is scanned, assuring correct component utilization for a given unit capacity and voltage. All condenser coils are leak tested with pressurization test to 550#’s and once installed and assembled, each units’ complete refrigerant system is helium leak tested. All units are fully charged from the factory for up to 15 feet of piping. All units are factory run tested. The RP15 has a 10-year conditional compressor and parts warranty (registration required).

Optional Accessories (Refer to accessory chart for model #)

Compressor Crankcase Heater

- Protects against refrigerant migration that can occur during low ambient operation

Compressor Sound Cover

- Reinforced vinyl compressor cover containing a 1½ inch thick batt of fiberglass insulation
- Open edges are sealed with a one-inch wide hook and loop fastening tape

Compressor hard Start Kit

- Single-phase units are equipped with a PSC compressor motor. This type of motor normally does not need a potential relay and start capacitor
- In conditions such as low voltage, this kit may be required to increase the compressor starting torque

Low Ambient Kit

- Heat Pump operate satisfactorily in the cooling mode down to 55°F outdoor air temperature without any additional controls
- Kit can be added in the field enabling unit to operate properly down to 0° in the cooling mode
- Crankcase heater and freezestat should be installed on compressors equipped with a low ambient kit

3"/6"/12"

- Gray high density polyethylene feet are available to raise unit off of mounting surface away from moisture

Heat Pumps

Brand	Product Category	SEER	Capacity BTU/HR	Major Series*	Voltage	Type	Controls	Minor Series**	Option Code
<u>R</u>	<u>P</u>	<u>15</u>	<u>24</u>	<u>A</u>	<u>J</u>	<u>1</u>	<u>N</u>	<u>A</u>	<u>*</u>
Ruud	P - Heat Pump	13 - 13 SEER 14 - 14 SEER 15 - 15 SEER 17 - 17 SEER 20 - 20 SEER	18 - 18,000 [5.28 kW] 24 - 24,000 [7.03 kW] 30 - 30,000 [8.79 kW] 36 - 36,000 [10.55 kW] 42 - 42,000 [12.31 kW] 48 - 48,000 [14.07 kW] 60 - 60,000 [17.58 kW]	A - 1st Design B - 2nd Design	J - 1ph, 208-230/60 C - 3ph, 208-230/60 D - 3ph, 460/60	1 - Single-stage V - Inverter P - Piston	C - Communicating N - Non-communicating	A - 1st Design	N/A

Air Conditioners (For Reference)

Brand	Product Category	SEER	Capacity BTU/HR [kW]	Major Series*	Voltage	Type	Controls	Minor Series**	Option Code
<u>R</u>	<u>A</u>	<u>14</u>	<u>24</u>	<u>A</u>	<u>J</u>	<u>1</u>	<u>N</u>	<u>A</u>	<u>*</u>
Ruud	A - Air Conditioners	13 - 13 SEER 14 - 14 SEER 16 - 16 SEER 17 - 17 SEER 20 - 20 SEER	18 - 18,000 [5.28 kW] 24 - 24,000 [7.03 kW] 30 - 30,000 [8.79 kW] 36 - 36,000 [10.55 kW] 42 - 42,000 [12.31 kW] 48 - 48,000 [14.07 kW] 60 - 60,000 [17.58 kW]	A - 1st Design	J - 1ph, 208-230/60 C - 3ph, 208-230/60 D - 3ph, 460/60	1 - Single-stage 2 - Two-stage V - Inverter	C - Communicating N - Non-communicating	A - 1st Design	N/A

Furnace Coils (For Reference)

Brand	Product Category	Type	Capacity BTU/HR	Width	Efficiency	Metering Device	Major Series*	Orientation	Casing	Minor Series**	Option Code
<u>R</u>	<u>C</u>	<u>F</u>	<u>24</u>	<u>17</u>	<u>S</u>	<u>I</u>	<u>A</u>	<u>M</u>	<u>C</u>	<u>A</u>	<u>*</u>
Ruud	C - Evap Coil F - Furn Coil H - Air-Handler Coil	F - Furn Coil H - Air-Handler Coil	24 - 24,000 [7.03 kW] 36 - 36,000 [10.55 kW] 48 - 48,000 [14.07 kW] 60 - 60,000 [17.58 kW]	14 - 14" 17 - 17.5" 21 - 21" 24 - 24.5"	S - Standard Eff. M - Mid Eff. H - High Eff.	T-TXV E-EEV P-Piston	A - 1st Design	M - Multi-poise	C - Cased U - Uncased	A - 1st Design	N/A

[] Designates Metric Conversions

90%+ AFUE Gas Furnaces (For Reference)

<u>R</u>	<u>96</u>	<u>V</u>	<u>A</u>	<u>70</u>	<u>2</u>	<u>3</u>	<u>17</u>	<u>M</u>	<u>S</u>	<u>A</u>
Brand	Series	Motor	Major Rev	Input BTU/HR [kW]	Stages	Air Flow	Cabinet Width	Configuration	Nox	Minor Rev
Ruud	90 - 90 AFUE	V - Variable speed	A - 1st Design	040 - 42,000 [12.31 kW]	1 - Single-stage	3 - up to 3 ton	14 - 14"	M - Multi-poise	X - Low Nox	A - 1st Design
	92 - 92 AFUE	T - Constant Torque		060 - 56,000 [16.41 kW]	2 - Two-stage	5 - 3 1/2 up to 5 ton	17 - 17.5"		S - Standard	
	95 - 95 AFUE			070 - 70,000 [20.51 kW]	M - Modulating		21 - 21"			
	96 - 96 AFUE			085 - 84,000 [24.62 kW]			24 - 24.5"			
	97 - 97 AFUE			100 - 98,000 [28.72 kW]						
		P - PSC		115 - 112,000 [32.82 kW]						

80% AFUE Gas Furnaces (For Reference)

<u>R</u>	<u>80</u>	<u>2</u>	<u>V</u>	<u>A</u>	<u>075</u>	<u>3</u>	<u>17</u>	<u>M</u>	<u>S</u>	<u>A</u>
Brand	Series	Stages	Motor	Major Rev	Input BTU/HR [kW]	Air Flow	Cabinet Width	Configuration	Nox	Minor Rev
Ruud	80 - 80+ AFUE	1 - Single-stage 2 - Two-stage	V - Variable speed T - Constant Torque (X-13) P - PSC premium S - PSC standard	A - 1st Design	050 - 50,000 [15 kW] 075 - 75,000 [22 kW] 100 - 100,000 [29 kW] 125 - 125,000 [37 kW] 150 - 150,000 [44 kW]	3 - up to 3 ton 4 - 2 1/2 to 4 ton 5 - 3 1/2 up to 5 ton	14 - 14" 17 - 17.5" 21 - 21" 24 - 24.5"	M - Multi D - Down Z - Down & zero clearance down flow	X - Low Nox S - Standard	A - 1st Design

Air Handlers (For Reference)

<u>R</u>	<u>H</u>	<u>1</u>	<u>T</u>	<u>36</u>	<u>17</u>	<u>S</u>	<u>T</u>	<u>A</u>	<u>N</u>	<u>A</u>	<u>000</u>	<u>*</u>
Brand	Product Category	Stages of Airflow	Motor Type	Capacity BTU/HR	Width	Coil Size	Metering Device	Major Series*	Controls	Voltage	Minor Series**	Factory Heat Cap Code
Ruud	H - Air Handler	1 - Single-stage 2 - Two-stage M - Modulating	V - Variable Speed T - Constant Torque P - PSC	24 - 24,000 [7.03 kW] 36 - 36,000 [10.55 kW] 48 - 48,000 [14.07 kW] 60 - 60,000 [17.58 kW]	14 - 14" 17 - 17.5" 21 - 21" 24 - 24.5"	S - Standard Efficiency M - Mid Efficiency H - High Efficiency	T - TEV E - EEV P - Piston	A - 1st Design	C - Communicating N - Non-communicating	A - 1ph, 115/60 J - 1ph, 208-240/60 D - 3ph, 480/60	A - 1st Design Design	00 - no factory heat with option code N/A

[] Designates Metric Conversions

Physical Data							
Model No. #	RP1518B	RP1524B	RP1530B	RP1536A	RP1542A	RP1548A	RP1560A
Nominal Tonnage	1.5	2.0	2.5	3.0	3.5	4.0	5.0
Valve Connections							
Liquid Line O.D. – in.	3/8	3/8	3/8	3/8	3/8	3/8	3/8
Suction Line O.D. – in.	3/4	3/4	3/4	3/4	7/8	7/8	7/8
Refrigerant (R410A) furnished oz. ¹	99	105	116	118	139	108	217
Compressor Type	Scroll						
Outdoor Coil							
Net face area – Outer Coil ft ²	9.1	11.1	17.3	19.8	19.8	24.2	28.3
Net face area – Inner Coil	—	—	—	—	—	—	—
Tube diameter – in.	3/8	3/8	3/8	3/8	3/8	3/8	3/8
Number of rows	1	1	1	1	1	1	1
Fins per inch	20	20	20	20	20	20	20
Outdoor Fan							
Diameter – in.	20	20	24	24	24	26	26
Number of blades	2	3	3	3	3	3	3
Motor hp	1/8	1/8	1/5	1/3	1/5	1/3	1/5
CFM	2411	2478	3852	3120	3815	4380	3655
RPM	1077	1075	825	910	825	870	850
watts	151	138	197	135	202	266	274
Shipping weight – lbs.	156	159	167	179	187	215	243
Operating weight – lbs.	133	152	160	172	180	208	236

Electrical Data							
Line Voltage Data (Volts-Phase-Hz)	208/230-1-60	208/230-1-60	208/230-1-60	208/230-1-60	208/230-1-60	208/230-1-60	208/230-1-60
Maximum overcurrent protection (amps) ²	15	25	25	35	40	40	50
Minimum circuit ampacity ³	12	15	18	23	24	26	31
Compressor							
Rated load amps	9	10.9	12.8	15.4	17.9	18.5	23.7
Locked rotor amps	47.5	62.9	67.8	83.9	112	124	152.5
Condenser Fan Motor							
Full load amps	0.7	0.7	1	2.8	1	2.8	1
Locked rotor amps	1.2	1.3	1.2	—	1.2	—	2.3
Line Voltage Data (Volts-Phase-Hz)	—	—	—	208/230-3-60	208/230-3-60	208/230-3-60	208/230-3-60
Maximum overcurrent protection (amps) ²	—	—	—	25	30	30	35
Minimum circuit ampacity ³	—	—	—	16	18	21	21
Compressor							
Rated load amps	—	—	—	10.4	13.5	13.8	15.9
Locked rotor amps	—	—	—	73	88	83.1	110
Condenser Fan Motor							
Full load amps	—	—	—	2.8	1	2.8	1
Locked rotor amps	—	—	—	—	1.5	—	2.3

¹Refrigerant charge sufficient for 15 ft. length of refrigerant lines. For longer line set requirements see the installation instructions for information about set length and additional refrigerant charge required.

²HACR type circuit breaker or fuse.

³Refer to National Electrical Code manual to determine wire, fuse and disconnect size requirements.

Accessories

Model No.	RP1518	RP1524	RP1530	RP1536	RP1542	RP1548	RP1560
Compressor crankcase heater	44-17402-44	44-17402-44	44-17402-44	44-17402-44	44-17402-45	Factory Standard	Factory Standard
Low ambient control	RXAD-A08	RXAD-A08	RXAD-A08	RXAD-A08	RXAD-A08	RXAD-A08	RXAD-A08
Compressor sound cover	68-23427-26	68-23427-26	68-23427-26	68-23427-26	68-23427-25	68-23427-25	68-23427-25
Compressor hard start kit	SK-A1	SK-A1	SK-A1	SK-A1	SK-A1	SK-A1	SK-A1
Low pressure control*	Factory Standard	Factory Standard	Factory Standard	Factory Standard	Factory Standard	Factory Standard	Factory Standard
High pressure control*	Factory Standard	Factory Standard	Factory Standard	Factory Standard	Factory Standard	Factory Standard	Factory Standard
Liquid Line Solenoid (24 VAC, 50/60 Hz)	Solenoid Valve	200RD2T3TVLC	200RD2T3TVLC	200RD2T3TVLC	200RD2T3TVLC	200RD2T3TVLC	200RD3T3TVLC
	Solenoid Coil	61-AMG24V	61-AMG24V	61-AMG24V	61-AMG24V	61-AMG24V	61-AMG24V
	Bi-flow kit*	KS30387	KS30387	KS30387	KS30387	KS30387	KS30387
Liquid Line Solenoid (120/240 VAC, 50/60 Hz)	Solenoid Valve	200RD2T3TVLC	200RD2T3TVLC	200RD2T3TVLC	200RD2T3TVLC	200RD2T3TVLC	200RD3T3TVLC
	Solenoid Coil	61-AMG120/240V	61-AMG120/240V	61-AMG120/240V	61-AMG120/240V	61-AMG120/240V	61-AMG120/240V
	Bi-flow kit*	KS30387	KS30387	KS30387	KS30387	KS30387	KS30387
Achiever Top Cap w/Label	91-101123-21	91-101123-21	91-101123-21	91-101123-21	91-101123-21	91-101123-21	91-101123-21
Heat Pump Riser – 6 inch	686020	686020	686020	686020	686020	686020	686020

*Bi-flow kits are required when installing a liquid line solenoid on a heat pump.

Weighted Sound Power Level (dBA)

Unit Size – Voltage, Series	Standard Rating (dBA)	TYPICAL OCTAVE BAND SPECTRUM (dBA without tone adjustment)						
		125	250	500	1000	2000	4000	8000
RP1518B	75.2	53.8	60.2	64.3	66	62.5	57.6	53.5
RP1524B	75.8	53.9	60.6	65.8	66.4	63.0	57.8	50.2
RP1530B	73.3	51.8	56.6	63.4	62.9	60.8	55.9	51.5
RP1536A	74.7	48.9	54.3	63.1	66.4	62.2	53.2	53.2
RP1542A	74.1	52.9	55.9	64	63.5	61.4	58	52.1
RP1548A	76.5	55.8	59	68.2	66.3	64.3	60.5	55.4
RP1560A	73.9	58.9	55.7	63.4	63.3	61.5	58.6	56.4

NOTE: Tested in accordance with AHRI Standard 270-08 (not listed in AHRI)

Thermostats



200-Series *
Programmable



300-Series *
Deluxe
Programmable

400-Series *
Special Applications/
Programmable



500-Series *
Communicating/
Programmable

Brand	Descriptor (3 Characters)	Series (3 Characters)	System (2 Characters)	Type (2 Characters)
UHC	-	TST	213	UN
UHC=Ruud	TST=Thermostat	200=Programmable 300=Deluxe Programmable 400=Special Applications/ Programmable 500=Communicating/ Programmable	GE=Gas/Electric UN=Universal (AC/HP/GE) MD=Modulating Furnace DF=Dual Fuel CM=Communicating	SS=Single-Stage MS=Multi-Stage

* Photos are representative. Actual models may vary.

For detailed thermostat match-up information,
see specification sheet form number T22-001.

Unit Dimensions

MODEL NUMBER	OPERATING						SHIPPING					
	H (Height)		L (Length)		W (Width)		H (Height)		L (Length)		W (Width)	
	INCHES	mm	INCHES	mm	INCHES	mm	INCHES	mm	INCHES	mm	INCHES	mm
RP1518B	25	635	29.75	755	29.75	755	26.75	679	32.38	822	32.38	822
RP1524B	25	635	29.75	755	29.75	755	26.75	679	32.38	822	32.38	822
RP1530B	31	787	33.75	857	33.75	857	32.75	831	32.38	822	32.38	822
RP1536A	35	889	33.75	857	33.75	857	36.75	933	36.38	924	36.38	924
RP1542A	35	889	33.75	857	33.75	857	36.75	933	36.38	924	36.38	924
RP1548A	39	990	35.75	908	35.75	908	40.75	1035	38.38	974	38.38	974
RP1560A	45	1143	35.75	908	35.75	908	46.75	1187	38.38	974	38.38	974

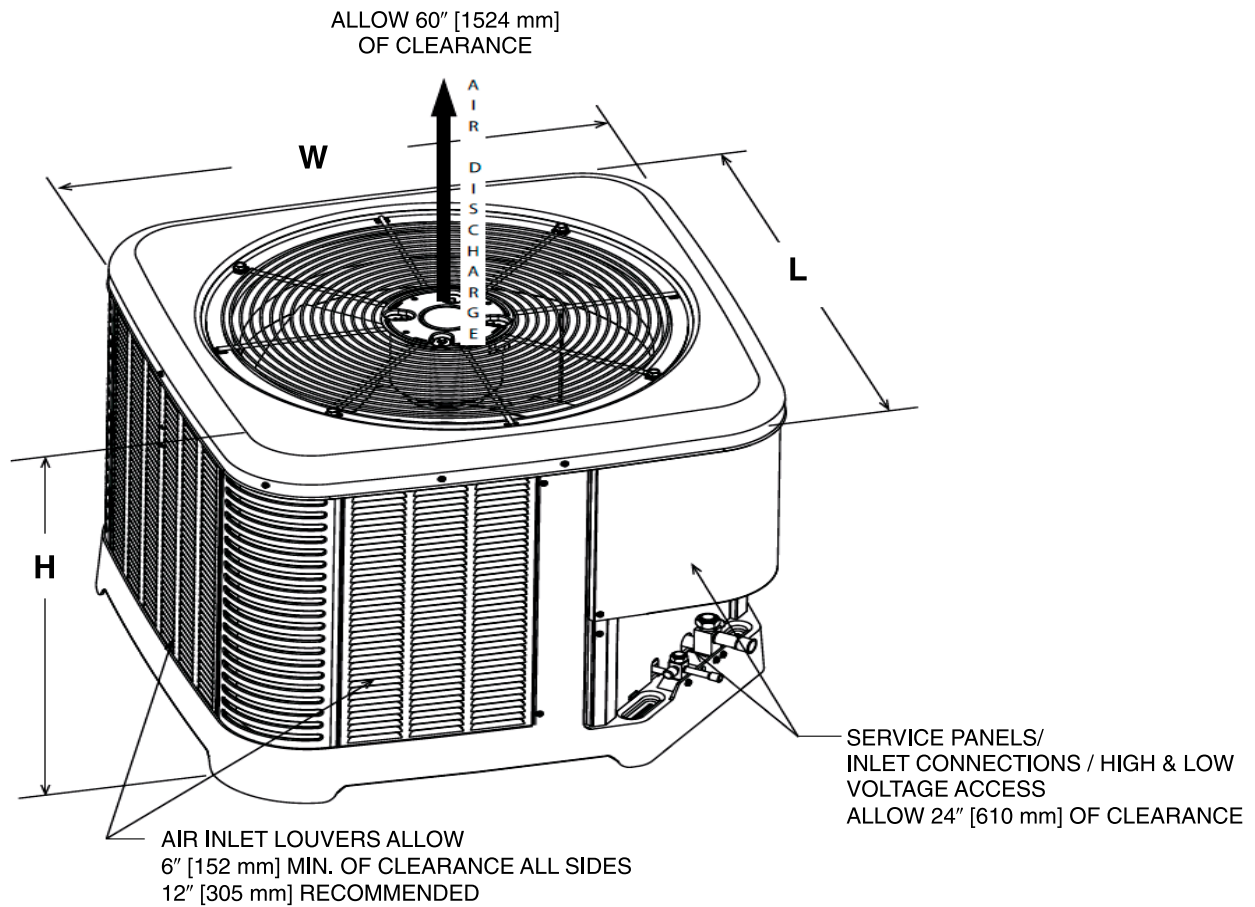

[] Designates Metric Conversions

ST-A1226-02-00