

TECHNICAL SPECIFICATIONS

C6 Indoor Coils

MODEL IDENTIFICATION CODE

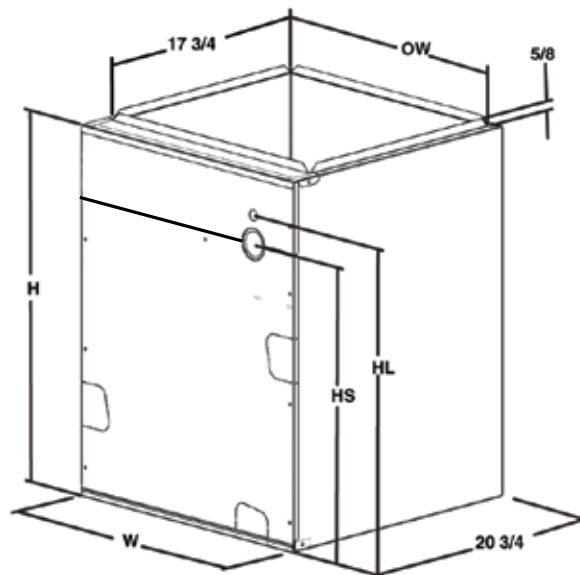
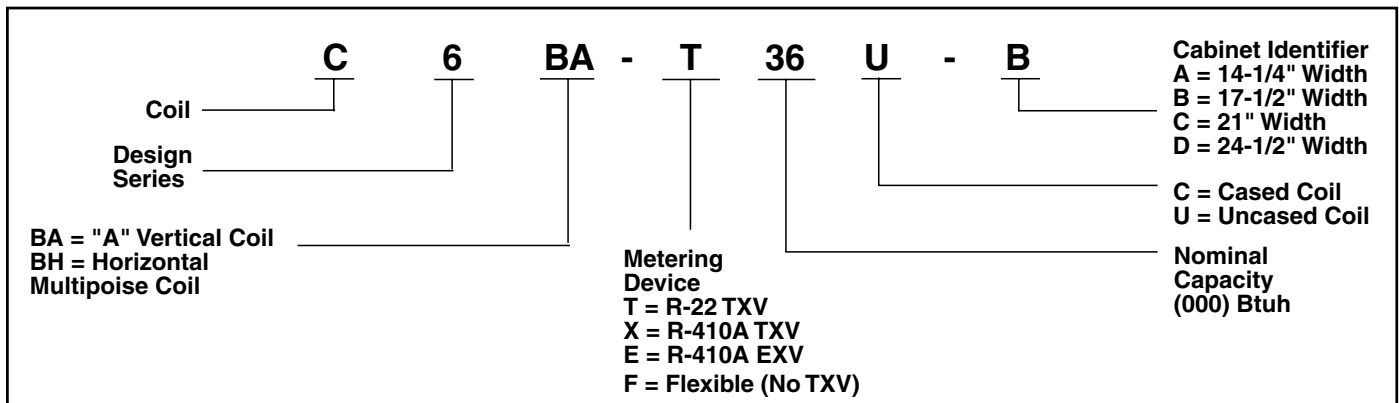

Figure 1. Cased Coil Wrapper

C6 CASED COIL WRAPPERS (SEE FIGURE 1)

SKU	Cabinet Identifier	Overall Width	Overall Height	Liquid Line Height	Suction Line Height	Opening Width
		W	H	HL	HS	OW
920256	A	14 1/4"	20 3/4"	17 1/2"	15 1/2"	12 7/8"
920257	A	14 1/4"	26 3/4"	23 1/2"	21 1/2"	12 7/8"
920258	B	17 1/2"	20 3/4"	17 1/2"	15 1/2"	16 1/8"
920259	B	17 1/2"	26 3/4"	23 1/2"	21 1/2"	16 1/8"
920260	C	21"	26 3/4"	23 1/2"	21 1/2"	19 5/8"
920261	C	21"	30 1/4"	27"	25"	19 5/8"
920262	D	24 1/2"	30 1/4"	27"	25"	23 1/8"

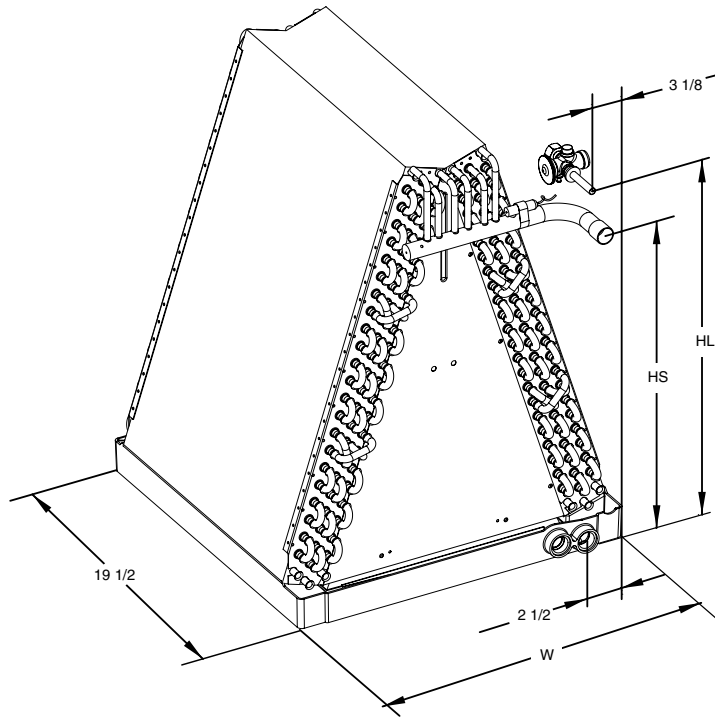

Figure 2. Uncased coil

C6 FLEXIBLE UNCASSED COIL DATA (SEE FIGURE 2)

Coil Model C6BA	F24-A	F36-A	F24-B	F36-B	F42-B	F48-C	F60-C	F48-D	F60-D
Face Area (ft ²)	4.18	4.18	4.18	4.18	5.58	5.58	6.42	5.58	6.42
Rows	3	3	3	3	3	3	3	3	3
Fins per inch	14	14	14	14	14	14	14	14	14
W - Width (in.)	12 3/4	12 3/4	16	16	16	19 1/2	19 1/2	23	23
H - Height (in.)	19	19	19	19	24 3/4	23 3/4	28 3/4	24	28 1/4
HL - Height of Liquid Line (in.)	17 1/2	17 1/2	17 1/2	17 1/2	23 1/2	23 1/2	27	27	27
HS - Height of Suction Line (in.)	15 1/2	15 1/2	15 1/2	15 1/2	21 1/2	21 1/2	25	25	25
Connection - Liquid Line	3/8	3/8	3/8	3/8	3/8	3/8	3/8	3/8	3/8
Connection - Suction Line	3/4	3/4	3/4	3/4	7/8	7/8	7/8	7/8	7/8
Horizontal Drain Kit	920265	920265	920265	920265	920266	920266	920267	920266	920267

C6 TXV INSTALLED UNCASSED COIL DATA (SEE FIGURE 2)

Coil Model C6BA, C6BH	T24-A X24-A	T30-A X30-A	X35-A	T24-B X24-B	X26-B	T30-B X30-B	X35-B	T36-B X36-B	T42-B X42-B	X47-B	X30-C	T36-C X36-C	X37-C	T42-C X42-C	X47-C	T48-C X48-C	T60-C X60-C	T42-D X42-D	T48-D X48-D	T60-D X60-D
Face Area (ft ²)	4.18	4.18	4.18	4.18	5.58	4.18	4.18	5.58	5.58	5.58	4.18	5.58	6.42	5.58	5.58	6.42	6.42	5.58	6.42	6.42
Rows	3	3	3	3	3	3	3	3	3	3	3	3	3	3	3	3	3	3	3	3
Fins per inch	14	14	14	14	14	14	14	14	14	14	14	14	14	14	14	14	14	14	14	14
Metering Device	TXV	TXV	TXV	TXV	TXV	TXV	TXV	TXV	TXV	TXV	TXV	TXV	TXV	TXV	TXV	TXV	TXV	TXV	TXV	TXV
Nominal Airflow (CFM)	800	1,000	1,000	800	1,200	1,000	1,200	1,200	1,400	1,200	1,000	1,200	1,200	1,400	1,400	1,600	2,000	1,400	1,600	2,000
Pressure drop at nom airflow (in. wc)	0.12	0.30	0.30	0.12	0.21	0.15	0.21	0.21	0.30	0.30	0.16	0.21	0.17	0.30	0.30	0.30	0.30	0.30	0.30	0.30
W - Width (in.)	12 3/4	12 3/4	12 3/4	16	16	16	16	16	16	16	19 1/2	19 1/2	19 1/2	19 1/2	19 1/2	19 1/2	19 1/2	23	23	23
H - Height (in.)	19	19	19	19	24 3/4	19	19	24 3/4	24 3/4	24 3/4	23 3/4	23 3/4	28 3/4	23 3/4	23 3/4	28 3/4	28 3/4	24	28 1/4	28 1/4
HL - Height of Liquid Line (in.)	17 1/2	17 1/2	17 1/2	17 1/2	23 1/2	17 1/2	17 1/2	23 1/2	23 1/2	23 1/2	23 1/2	23 1/2	27	23 1/2	23 1/2	27	27	27	27	27
HS - Height of Suction Line (in.)	15 1/2	15 1/2	15 1/2	15 1/2	21 1/2	15 1/2	15 1/2	21 1/2	21 1/2	21 1/2	21 1/2	21 1/2	25	21 1/2	21 1/2	25	25	25	25	25
Connection - Liquid Line	3/8	3/8	3/8	3/8	3/8	3/8	3/8	3/8	3/8	3/8	3/8	3/8	3/8	3/8	3/8	3/8	3/8	3/8	3/8	3/8
Connection - Suction Line	3/4	3/4	3/4	3/4	3/4	3/4	3/4	7/8	7/8	7/8	3/4	7/8	7/8	7/8	7/8	7/8	7/8	7/8	7/8	7/8
Horizontal Drain Kit	920265	920265	920265	920265	920266	920265	920265	920266	920266	920266	920266	920266	920267	920266	920266	920267	920267	920266	920267	920267