

# Class 125 Bronze Ring Check® Valves

Inline lift type • resilient discs • spring actuated

125 PSI/8.6 bar saturated steam to 353° F/178° C (PTFE Disc)  
250 PSI/17.2 bar non-shock cold working pressure

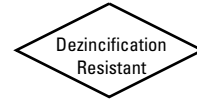

## MATERIAL LIST

PART	SPECIFICATION
1. Body	Bronze ASTM B584 Alloy C84400
2. Stem	Stainless Steel ASTM A 582 Alloy C30300
3. Spring	316 Stainless Steel
4. Disc Holder	Stainless Steel Type 301
5. Disc	Water, Oil or Gas (Buna-N) Steam (PTFE) (Y)
6. Seat Screw	Stainless Steel ASTM A276 Alloy S43000
7. Body End	Bronze ASTM B584 Alloy C84400



**T-480**  
Threaded



**S-480**  
Solder

## DIMENSIONS—WEIGHTS—QUANTITIES

Size	Dimensions						T-480		S-480		Master Ctn. Qty.	
	A		B		C		Lbs.	mm.	Lbs.	Kg.		
In.	mm.	In.	mm.	In.	mm.	In.	mm.	Lbs.	mm.	Lbs.	Kg.	
3/8	10	2.00	51	1.38	35	1.44	37	0.41	0.19	0.44	0.20	100
1/2	15	2.06	52	1.38	35	1.19	30	0.36	0.16	0.40	0.18	100
3/4	20	2.25	57	1.63	41	1.31	33	0.48	0.22	0.52	0.24	100
1	25	2.63	67	2.00	51	1.50	38	0.77	0.35	0.85	0.39	50
1 1/4	32	2.94	75	2.38	60	1.69	43	1.14	0.51	1.28	0.58	30
1 1/2	40	3.31	84	2.75	70	2.00	51	1.63	0.74	1.75	0.79	30
2	50	3.69	94	3.38	86	2.31	59	2.27	1.03	2.70	1.23	10

Ordering: The T-480 and S-480 both have standard Buna-N Discs.  
Also available with PTFE (Y) Discs; specify T-480-Y or S-480-Y.  
3/8" thru 2" require 1/2 pound pressure to open.

Install 5 pipe diameters minimum downstream from pump discharge or changes in direction to avoid flow turbulence. Flow straighteners may be required in extreme cases.

Note: On pump discharge, the preferred check valves are:  
- inline, spring assisted, center-guided, lift checks.

NIBCO® Check Valves may be installed in both horizontal and vertical lines with upward flow or in any intermediate position.

Warning – Do Not Use For Reciprocating Air Compressor Service.

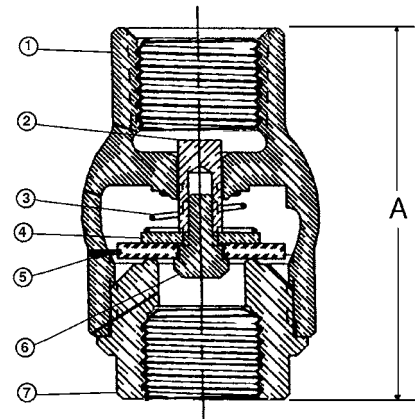

**T-480-Y (PTFE Disc)**  
NPT x NPT

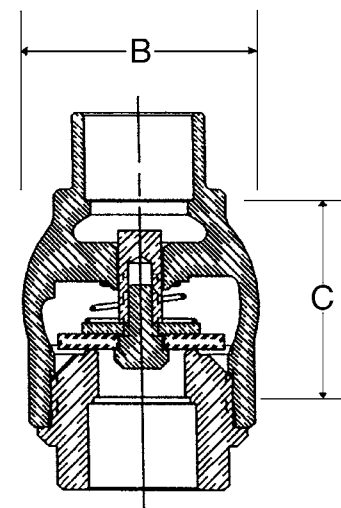

**S-480-Y (PTFE Disc)**  
C x C

◆ For detailed Operating Pressure, refer to Pressure Temperature Chart on page 114.

Visit our website for the most current information.