



# SERVICE PARTS LIST

**BULLETIN NO.**  
54-10-0250

SPECIFY CATALOG NO. AND SERIAL NO. WHEN ORDERING PARTS		REVISED BULLETIN	DATE
<b>SUPER HAWG®</b>			Oct. 2016
CATALOG NO. 1680-20	STARTING SERIAL NUMBER 407A	WIRING INSTRUCTION <b>58-01-0695</b>	

**EXAMPLE:**  
Component Parts (Small #) Are Included  
When Ordering The Assembly (Large #).

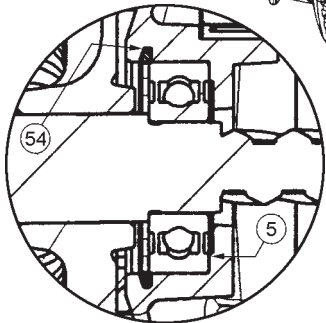
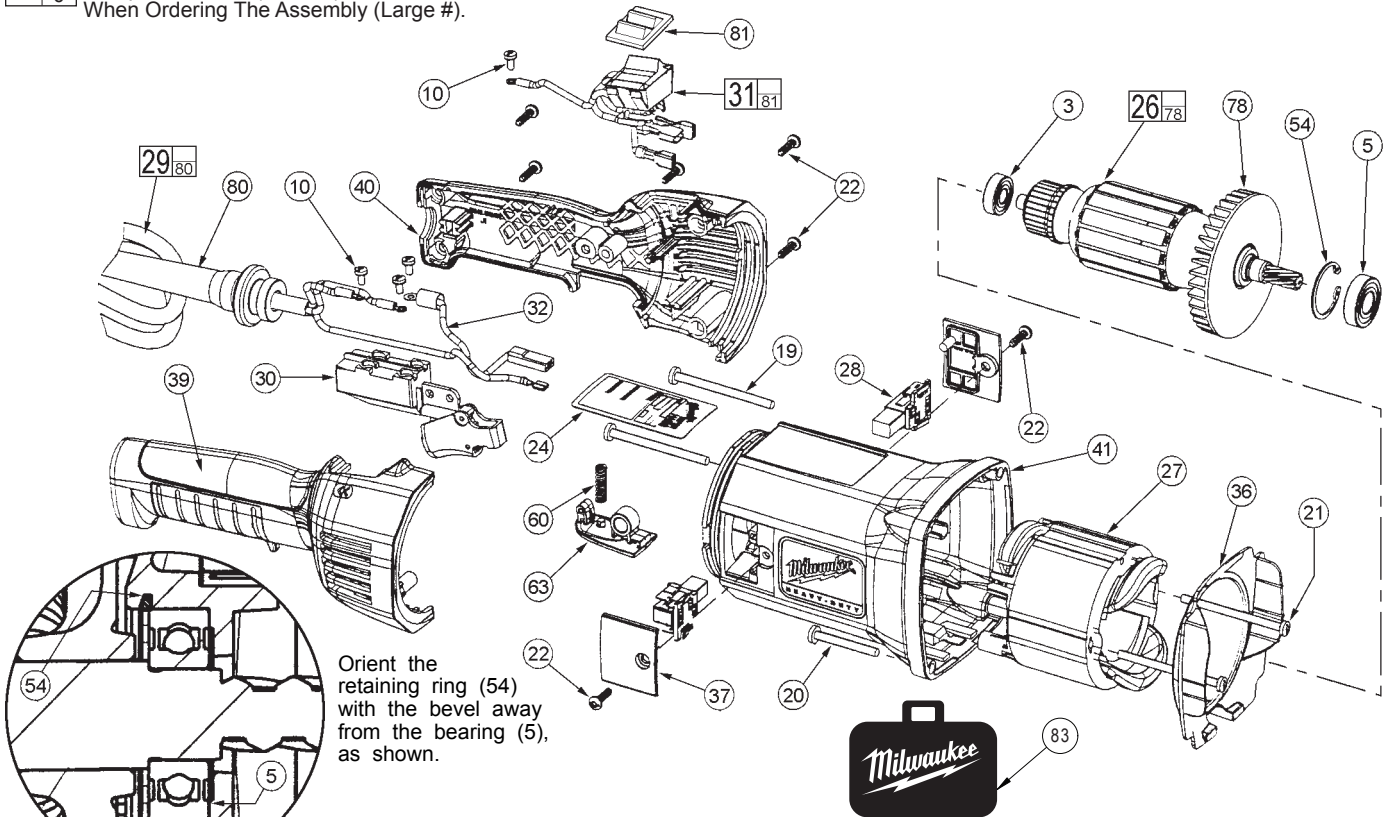

Orient the retaining ring (54) with the bevel away from the bearing (5), as shown.

**SERVICE DETAILS FOR PARTS ON THE BACK PAGE**

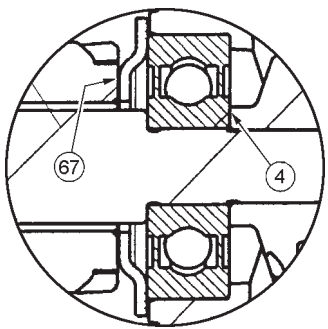

Orient the bearing retainer (67) with the offset away from the bearing (4), as shown.

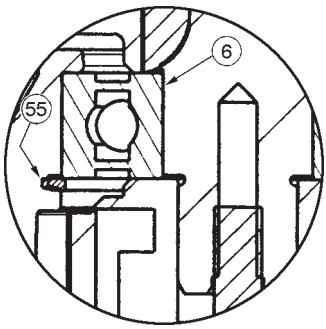

Orient the retaining ring (55) with the bevel facing away from the bearing (6), as shown.

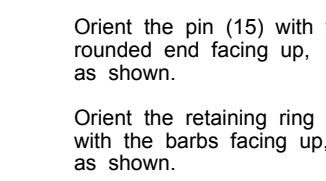

Orient the pin (15) with the rounded end facing up, as shown.

Orient the retaining ring (53) with the barbs facing up, as shown.

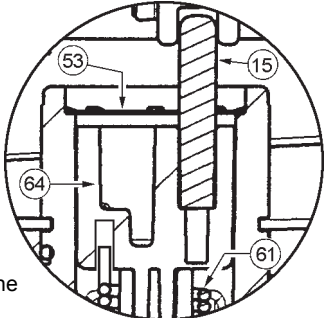

Insert the straight end of the spring (61) into the hole in the bottom of the shift disk (64).

FIG.	PART NO.	DESCRIPTION OF PART	QTY.
3	02-04-0852	Ball Bearing	(1)
5	02-04-1204	Ball Bearing	(1)
10	05-78-0305	M3.5 x 0.6 x 7mm Pan Hd. Slotted T-15	(4)
19	06-82-5554	10-24 x 2.375 Taptite T-25	(2)
20	06-82-5584	10-24 x 1.50 Taptite T-25	(2)
21	06-82-7375	8-16 x 2.50 Slotted Plastite T-20	(2)
22	06-82-9220	K40 x 5/8 Slotted PT T-20	(7)
24	12-98-7305	Service Nameplate	(1)
26	16-50-1095	Armature Assembly	(1)
27	18-50-1095	Field	(1)
28	22-20-0150	Brush Holder Assembly	(2)
29	22-64-1260	Cord Assembly	(1)
30	23-66-2270	On/Off Switch	(1)
31	23-66-2365	Reversing Switch Assembly	(1)
32	23-94-2270	Lead Wire Assembly	(1)
36	31-05-0240	Baffle	(1)
37	31-15-0595	Brush Cover	(2)
39	31-44-2165	Handle Half - Right	(1)
40	31-44-2170	Handle Half - Left	(1)
41	31-50-1780	Motor Housing with Trace	(1)
54	34-80-2021	Beveled Internal Retaining Ring	(1)
60	40-50-0265	Rotation Button Spring	(1)
63	42-42-0490	Rotation Release Button	(1)
78	22-84-0085	Fan	(1)
80	44-76-0355	Cord Protector	(1)
81	42-38-0280	Rocker Boot	(1)
83	48-55-1680	Accessory Carrying Case	(1)

**SEE REVERSE SIDE**

**Fig. 23, No. 32-10-1056 Clutch Assembly-** has been "calibrated" at the factory and requires no "run-in".

When servicing individual parts of the Clutch Assy., care should be taken to thoroughly grease all components during re-assembly. Failure to correctly grease the components can damage mechanism, making it inoperable. The tool must be "run-in", activating the clutch for a minimum of 3 seconds. The acceptable static torque range of the Clutch Assembly is 90-50 ft.-lbs.

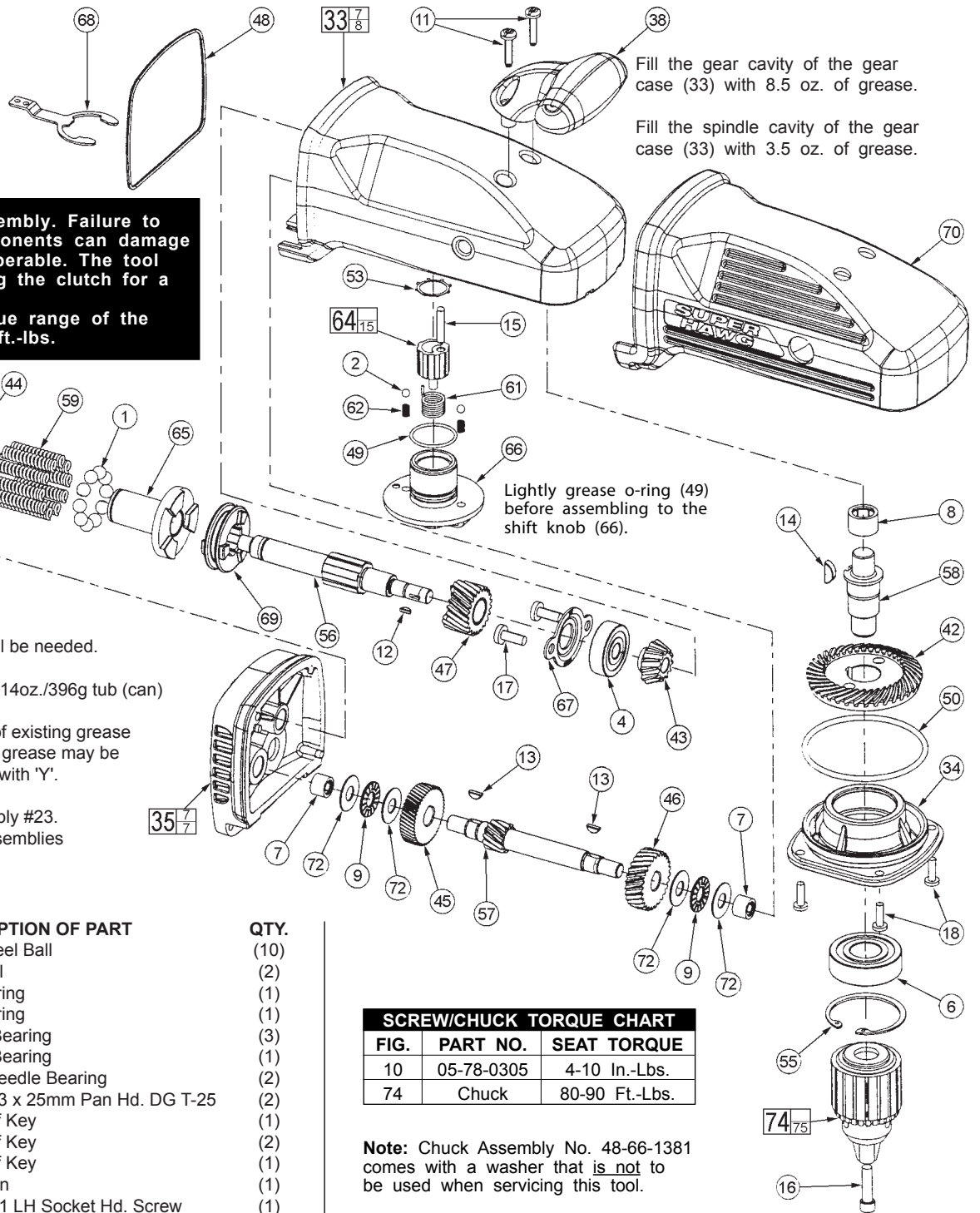

**LUBRICATION NOTES:**

Type 'Y' Grease No. 49-08-5270, 6oz./170g tube

The entire amount of two tubes will be needed.

or

Type 'Y' Grease No. 49-08-5275, 14oz./396g tub (can)

When servicing, remove 90-95% of existing grease prior to installing Type 'Y'. Original grease may be similar in color but not compatible with 'Y'.

**DO NOT** wash Clutch Hub Assembly #23. Prior to reinstalling, clean gear assemblies with a clean dry cloth.

FIG.	PART NO.	DESCRIPTION OF PART	QTY.
1	02-02-0340	11/32 Steel Ball	(10)
2	02-02-1300	5mm Ball	(2)
4	02-04-1055	Ball Bearing	(1)
6	02-04-2031	Ball Bearing	(1)
7	02-50-7000	Needle Bearing	(3)
8	02-50-7005	Needle Bearing	(1)
9	02-80-0180	Thrust Needle Bearing	(2)
11	05-88-9910	M5 x 1.23 x 25mm Pan Hd. DG T-25	(2)
12	06-42-0800	Woodruff Key	(1)
13	06-42-1900	Woodruff Key	(2)
14	06-42-2400	Woodruff Key	(1)
15	06-65-2010	Dowel Pin	(1)
16	06-75-3150	1/4-20 x 1 LH Socket Hd. Screw	(1)
17	06-82-5360	1/4-20 x .625 Taptite T-30	(2)
18	06-82-5411	10-24 x .625 Taptite T-25	(4)
23	32-10-1056	Clutch Assembly	(1)
33	28-14-2546	Gearcase Assembly	(1)
34	28-20-2600	Gearcase Cover	(1)
35	28-28-2186	Diaphragm Assembly	(1)
38	31-44-2060	Gearcase Front Handle	(1)
42	32-05-1515	Spiral Bevel Gear	(1)
43	32-05-1520	Spiral Bevel Pinion	(1)
44	32-10-1055	2nd Intermediate Gear - Low	(1)
45	32-42-1380	1st Intermediate Gear	(1)
46	32-42-1400	1st Intermediate Gear - High	(1)
47	32-44-1340	2nd Intermediate Gear - High	(1)
48	34-40-0230	Gearcase Seal	(1)
49	34-40-4545	O-Ring	(1)
50	34-40-4550	O-Ring	(1)
51	34-60-1450	E-Ring	(1)
52	34-60-1455	External Retaining Ring	(1)
53	34-80-1800	Internal Retaining Ring	(1)
55	34-80-2980	Internal Beveled Retaining Ring	(1)
56	36-18-0585	Intermediate Shaft	(1)

**SCREW/CHUCK TORQUE CHART**

FIG.	PART NO.	SEAT TORQUE
10	05-78-0305	4-10 In.-Lbs.
74	Chuck	80-90 Ft.-Lbs.

**Note:** Chuck Assembly No. 48-66-1381 comes with a washer that is not to be used when servicing this tool.

FIG.	PART NO.	DESCRIPTION OF PART	QTY.
57	36-66-1225	1st Intermediate Pinion - Low	(1)
58	38-50-4460	Spindle	(1)
59	40-50-0260	Clutch Spring	(10)
61	40-50-8585	Torsion Spring	(1)
62	40-50-8690	Detent Spring	(2)
64	43-06-0696	Shifting Disk Assembly	(1)
65	43-78-0135	Clutch Hub Assembly	(1)
66	43-98-0665	Shifting Knob	(1)
67	44-86-0040	Bearing Retainer	(1)
68	44-86-0045	Retaining Fork	(1)
69	44-90-0575	Shifting Ring	(1)
70	45-12-0625	Gearcase Insulator	(1)
71	45-88-0255	Washer	(2)
72	45-88-0395	Thrust Washer	(4)
74	48-66-1381	Chuck	(1)
75	48-66-3280	Chuck Key (Not Shown)	(1)
76	48-66-4040	Chuck Key Holder (Not Shown)	(1)
77	49-15-0151	Side Handle Assembly (Not Shown)	(1)