

530 Bronze Swing Check Valve • Spec Sheet



FEATURES & BENEFITS

- ISO-9002
- Bronze Swing Check Valve
- 300 WOG Non-Shock
- 150 WSP
- Horizontal Pattern
- Threaded Cap
- Threaded Ends Conform to ANSI Standards B2.1
- Valves are Tested in Accordance w/MSS-SP-82

Applications: Commercial, Light Industrial
for Water, Oil, Gas and Steam

DIMENSIONS

Size	Part #	H	L
3/8"	530T02	1.42	2.09
1/2"	530T03	1.42	2.09
3/4"	530T04	1.56	2.36
1"	530T05	1.77	2.62
1-1/4"	530T06	2.07	3.19
1-1/2"	530T07	2.17	3.55
2"	530T08	2.74	4.22
2-1/2"	530T09	3.09	5.14
3"	530T10	3.80	5.77
4"	530T11	4.26	6.84

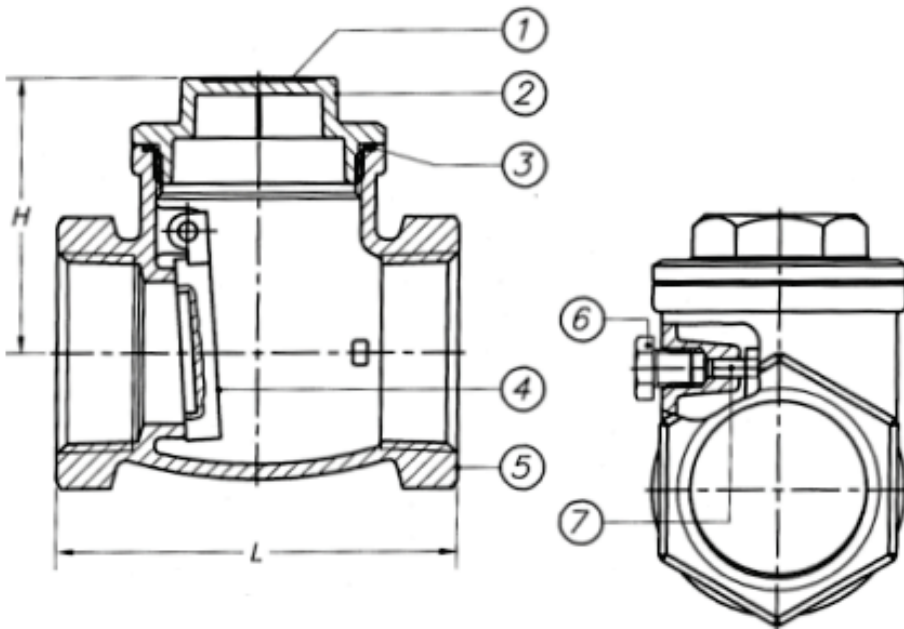

MATERIAL SPECIFICATIONS

No.	Part	Material
1	Name Plate	Aluminum A1100
2	Cap	Bronze B62 C83600
3	Packing	Fibre "H"
4	Disc	Bronze B62 C83600
5	Body	Bronze B62 C836001
6	Bolt	Brass B16 C36000
7	Pin	Brass B124 C37700

MATCO-NORCA
Global sourcing. National compliance. Local service.

CALIFORNIA 5593 Fresca Dr., La Palma CA 90623 • Toll Free: 866-532-8306 • Fax: 866-532-8307
TEXAS 1150 Silber Rd., Houston TX 77055 • Toll Free: 800-935-5456 • Fax: 713-680-2999
NEW YORK PO Box 27, Rt. 22, Brewster NY 10509 • Toll Free: 800-431-2082 • Fax: 845-278-9056
 WEB: www.matco-norca.com EMAIL: mail@matco-norca.com