

"QUARTERHORSE"- 1/4 TURN WALL HYDRANT WITH WARM CLIMATE HYDRANT

INTEGRAL VACUUM BREAKER AND STAINLESS STEEL BOX BOX TYPE WITH CONCEALED HOSE CONNECTION

FUNCTION: Provides a concealed hose connection with integral vacuum breaker. For installation in exterior or interior walls where there is no danger of freezing. The stainless steel recessed box conceals the nozzle and operating mechanism. The locking cover prevents unauthorized use.

1/4 Turn of the Key Allows Full Flow to Be Obtained

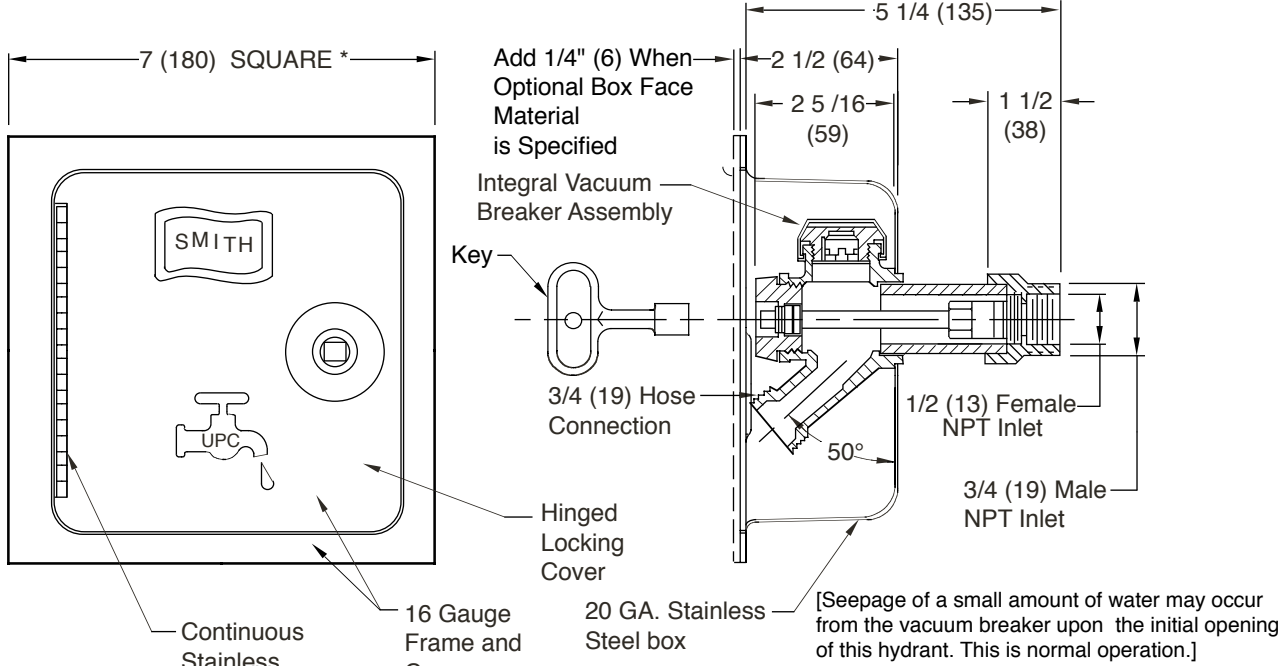

[Seepage of a small amount of water may occur from the vacuum breaker upon the initial opening of this hydrant. This is normal operation.]

Installer is responsible for providing a 100% watertight positive seal at the hydrant to box interface and hydrant to wall interface. Seal all interior joints, seams, gasket seams/closures including around the hydrant box flange with an appropriate sealant recommended by a sealant manufacturer. NOTE: Jay R. Smith does not warrant the performance or life expectancy of the sealant material.

REGULARLY FURNISHED:

Bronze Nickel Plated Quarter Turn Hydrant with Hose Connection, Integral Vacuum Breaker, "T" Handle Key, and Stainless Steel Box with Full 180° Cover Opening.

VARIATIONS:

- Cylinder -CL
- 1"(25) Hose Connection -HC1
- 1"(25) Male NPT Inlet Connection -IC1
- "Water" on Cover-W

OPTIONAL MATERIALS:

- Nickel Bronze Box Face -NB
- Polished Bronze Box Face -PB
- Rough Bronze Box Face -RB

**Add 3/4" (19) to Overall Length When Specified

- NOTES:**
- * 1. Recommended wall opening 6"(150) x 6"(150). Hydrant shall be in the vertical position only, the hose connection must be on the bottom.
 2. All Jay R. Smith hydrants are manufactured with "NO-LEAD" brazing rings, and USDA approved lubricants.
 3. When an Optional Box Face Material is Specified a Concealed Hinge Will be Provided, also add 1/4"(6) to Flange Thickness.
 5. The AB1953, California Lead Law, and NSF/ANSI Standard 61-2008 - Drinking Water System Components are not applicable to Jay R. Smith hydrants as they do not convey/dispense water for human consumption through drinking or cooking.
 6. Dimensions shown in parentheses are in millimeters.
 7. **FOR IRRIGATION PURPOSES ONLY.**

PATENTED

5509QT-SAP

R Q P N	7-19-16 1-31-13 10-7-09 7-5-95	Added Note Revised Notes Revised Notes Added Millimeters	TBW TBW RN EMB	BW CL CL BS	WEIGHT POUNDS	VOLUME CUBIC FEET	FIGURE NUMBER 5509QT-SAP
REV.	DATE	DESCRIPTION	BY	CKD. BY			

WE CAN ASSUME NO RESPONSIBILITY FOR USE OF SUPERSEDED OR VOID DATA

HYDRANT PARTS LIST

Installer is responsible for providing a 100% watertight positive seal at the hydrant to box interface and hydrant to wall interface. Seal all interior joints, seams, gasket seams/closures including around the hydrant box flange with an appropriate sealant recommended by a sealant manufacturer. NOTE: Jay R. Smith does not warrant the performance or life expectancy of the sealant material.

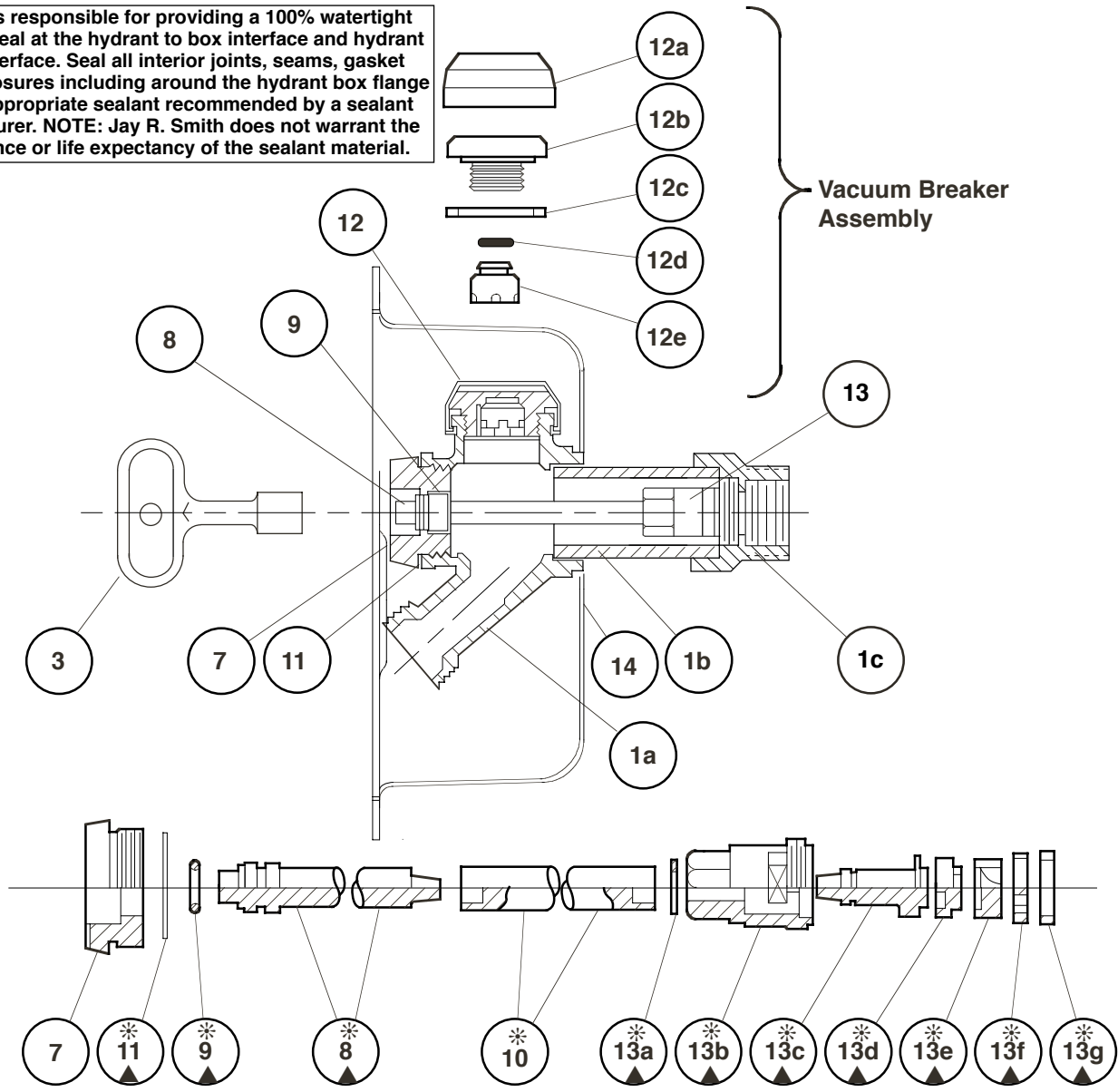

DRAWING NUMBER: S5509QTSAPBS
 SIZE: A
 SCALE: NONE
 DATE: 12-28-90
 APPROVED BY:
 CHECKED BY:
 DRAWN BY: EMB
 DIMENSIONS ARE SUBJECT TO MANUFACTURERS TOLERANCE AND CHANGE WITHOUT NOTICE
 WE CAN ASSUME NO RESPONSIBILITY FOR USE OF SUPERSEDED OR VOID DATA

▲ These Replacement Parts Available in HPRK-7

* These Parts Accessible from Face of Hydrant by Removing Face Nut.

HYDRANT PARTS LIST			
NO.	DESCRIPTION	NO.	DESCRIPTION
1	Head/Casing Assembly	10	Operator Rod
1a	Head	11	Face Nut Washer
1b	Casing	12	Vacuum Breaker Assembly
1c	Valve Housing	12a	VB Cap
3	Key	12b	VB Body
7	Face Nut	12c	VB Washer
8	Actuator Shaft	12d	VB "O" Ring
9	Actuator "O" Ring	12e	VB Piston
		13	Valve Body Assembly
		13a	Retaining Ring
		13b	Valve Body
		13c	Valve Actuator
		13d	Nylon Thrust Washer
		13e	Rotating Ceramic Disc
		13f	Fixed Ceramic Disc
		13g	Silicon Rubber Seal
		14	Backer Plate w/Screws

D	7-19-16	Added Note	TBW	BW	WEIGHT POUNDS	VOLUME CUBIC FEET	FIGURE NUMBER 5509QT-SAP-BS
C	11-12-91	Update Figure	TWK	BS			
B	10-25-91	Update Figure Number	TWK	JCS			
REV.	DATE	DESCRIPTION	BY	CKD. BY			