

MC Cable Connector

Features

- UL listed for use with MC, AC, FMC, RWFM, MCI, MCI-A and HCF cables
- Tri-combo screw head

Applications

- Dry location use only: Use to connect NM, armored or metal clad cable to box or enclosure
- Use to connect steel or aluminum FMC, AC, MC, HCF cables and aluminum MCC and MCI-A cable to box or enclosure

Standard Material

- Zinc die cast
- Zinc plated steel strap

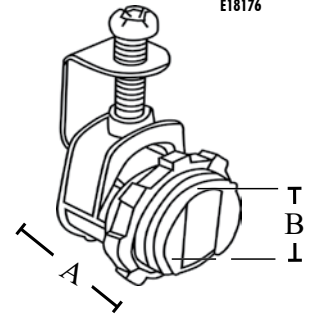

Catalog Number	UPC	Size	KO	Unit Carton	Ship Case	Weight/Case	Inches	
							A	B (Min.-Max.)
170	11380	3/8"	1/2"	50	500	40	.935	.40-.61

Catlog Number	KO Size	Size	Cable type	Cable Size	Opening MAX.	Opening MIN.	Wire Bundle Diameter MIN.	Wire Bundle Diameter MAX.
170	1/2"	3/8"	AC Steel	14/2 – 8/2	0.65	0.475	0.210	0.450
			AC STEEL HCF	14/2 – 8/2	0.65	0.475	0.220	0.460
			AC ALUMINUM	14/2 – 8/2	0.665	0.464	0.210	0.450
			AC ALUM HCF	14/2 – 8/2	0.665	0.464	0.220	0.460
			MCI STEEL	14/2 – 10/4	0.625	0.455	0.220	0.385
			MCI ALUMINUM	14/2 – 10/4	0.625	0.455	0.220	0.385
			MCI-A	14/2 – 10/4	0.565	0.385	0.220	0.390
			MCI-A HCF	14/2 – 10/4	0.565	0.385	0.240	0.440
			MC-PCS STEEL	12/2 - 12/3	0.610	0.529	0.360	0.380
			MC-PCS ALUMINUM	12/2 - 12/3	0.610	0.529	0.360	0.380
			FLEX CONDUIT	3/8"	0.610	0.560	---	---