

Gem•2® Flushometer

Manual Flushometers

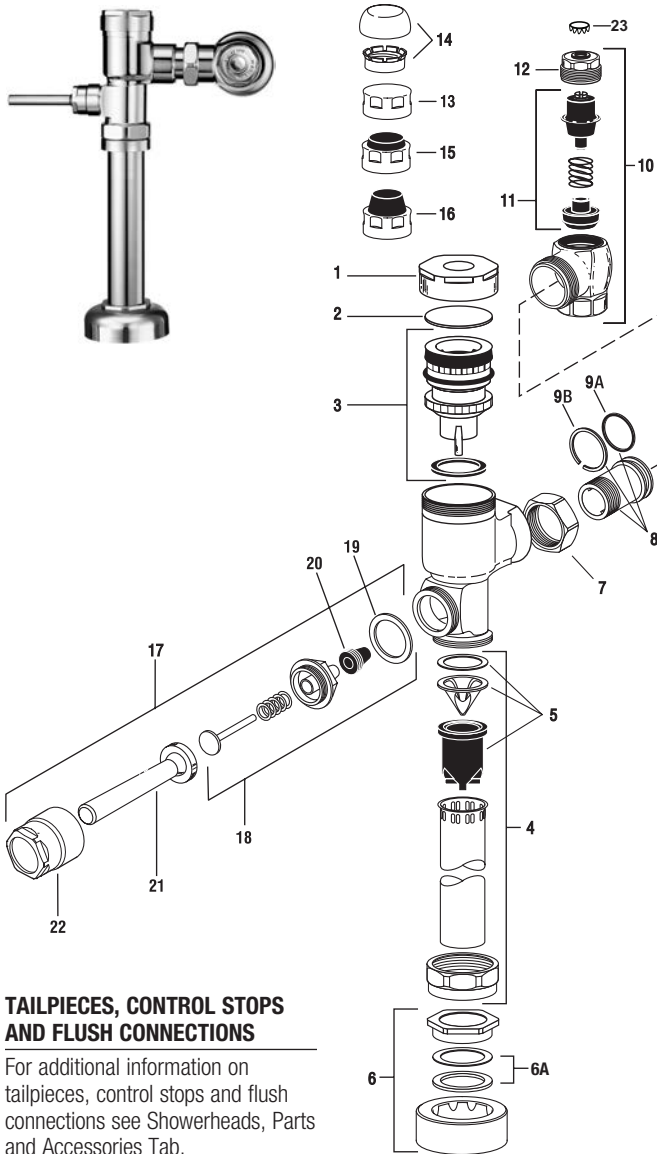

TAILPIECES, CONTROL STOPS AND FLUSH CONNECTIONS

For additional information on tailpieces, control stops and flush connections see Showerheads, Parts and Accessories Tab.

ITEM 6A. SLIP JOINT GASKETS AND RINGS

Size	Code No.	Part No.	Description
1-1/2"	5306058	F-3	Red Friction Ring
	5322001	VBF-5	Black Slip Joint Gasket
	0319086/5319086	S-30	Flexible Seat
	0319079	S-21	Rigid Seat (rubber over brass)
1-1/2" x 1-1/4"	0396062	F-105	Slip Joint Gasket – Rigid
1-1/4"	5306057	F-3	Red Friction Ring
	5322176	VBF-5	Black Slip Joint Gasket
	0307052/5307052	G-21	Rigid Seat (rubber over brass)
1"	5306056	F-3	Red Friction Ring
	5306115	F-5	Black Slip Joint Gasket
3/4"	5306055	F-3	Red Friction Ring
	5306113	F-5	Black Slip Joint Gasket

PARTS LIST

Item No.	Code No.	Part No.	Description
1.	0307142	G-105	CP Cover
2.	0307139	G-106	Slip Disc
3.	3307135	G-1022-A	Piston Kit – 1.28 gpf/4.8 Lpf Water Closet
	0307193	G-1007-A	Piston Kit – 3.5 gpf/13.2 Lpf Water Closet
	0307195	G-1016-A	Piston Kit – 1.6 gpf/6 Lpf Water Closet
	0307192	G-1009-A	Piston Kit – 1.5 gpf/5.7 Lpf Urinal
	0307185	G-1017-A	Piston Kit – 1.0 gpf/3.8 Lpf Urinal
	3307133	G-1018-A	Piston Kit – 0.5 gpf/1.9 Lpf Urinal
	3307134	G-1019-A	Piston Kit – 2.4 gpf/9.0 Lpf Water Closet
	3307136	G-1023-A	Piston Kit – 0.125 gpf/0.5 Lpf Urinal
	3307137	G-1024-A	Piston Kit – 0.25 gpf/1.0 Lpf Urinal

PISTON KITS FOR OLD STYLE ADJUSTABLE GEM FLUSHOMETERS

	0307043	G-1003-A	Piston Kit – Water Closet
	0307044	G-1002-A	Piston Kit – Urinal

ALL PISTON KITS INCLUDE G-21 MAIN SEAT (See next page)

4.	5323005	V-500-AA	3/4" x 9" Vacuum Breaker – 6 per package
	5323006	V-500-AA	1-1/4" x 9" Vacuum Breaker – 6 per package
	5323007	V-500-AA	1-1/2" x 9" Vacuum Breaker – 6 per package
5.	3323192	V-551-A	Vacuum Breaker Repair Kit
6.	3332002	CR-1010-A	1-1/2" (38 mm) Spud Coupling
	3332001	CR-1009-A	1-1/4" (32 mm) Spud Coupling
	3332000	CR-1008-A	3/4" (19 mm) Spud Coupling

6A. SEE SLIP JOINT GASKETS AND RINGS TABLE BELOW LEFT

7.	0308676	H-550	Stop Coupling
8.	0308801	H-551-A	Adjustable Tailpiece 2-1/16" (Standard Length)
9A.	5308696	H-553	O-ring – 24 per package
9B.	5308381	H-552	Locking ring – 12 per package
10.	3308876	H-790-A	1" Screwdriver Bak-Chek® Stop CP – complete
	3308875	H-790-A	3/4" Screwdriver Bak-Chek® Stop CP – complete
11.	3308853	H-541-A	Control Stop Repair Kit*
	3308856	H-543-A	Control Stop Repair Kit**
12.	0308612	H-622	CP Bonnet*
	0308843	H-577	CP Bonnet** – OBSOLETE
13.	3308840	H-573-A	Control Stop Cap**
14.	3388017	H-1017	Flow Control (HEU Only) (Not Shown)
15.	3308866	H-574	Control Stop w/Bumper (-YO Variation)*
16.	3308867	H-576	Control Stop w/Extended Bumper (-YG Variation)*

HANDLE REPAIR KIT

17.	0307100	G-143	Handle Assembly
18.	5307074	G-50-A	Handle Repair Kit – 6 per package
19.	5307065	G-35	Handle Gasket – 48 per package
20.	5302297	B-39	Handle Seal – 12 per package
21.	0307024	G-145	Handle Grip
22.	0307020	G-144	Handle Socket
23.	3308840	H-528	Control Stop Plug CP* Standard on XL

*For use with 1" and 3/4" H-700-A and 1" H-600-A Bak-Chek® screwdriver control stop
 **For use with 3/4" H-600-A Bak-Chek® screwdriver control stop