

UPPERCUT® Dual-Flush Flushometer

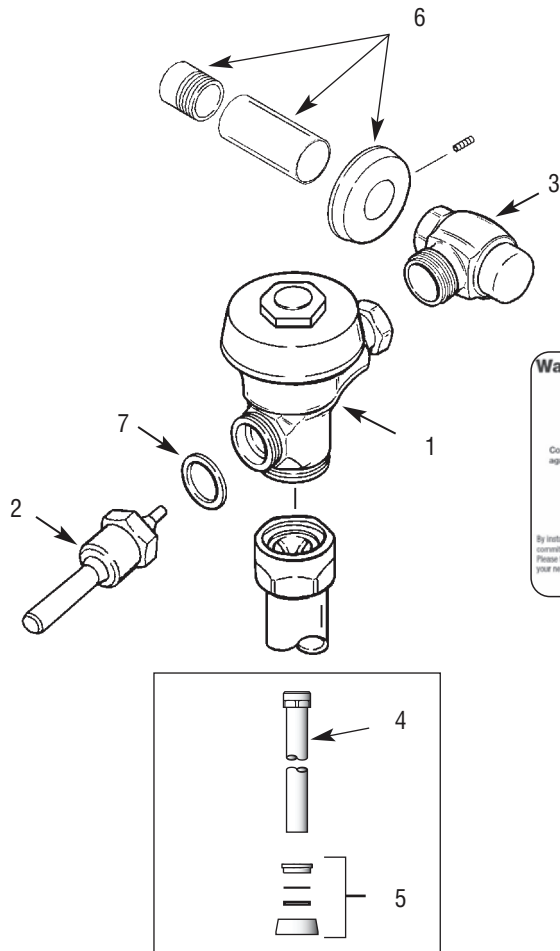

PARTS LIST

Item No.	Code No.	Part No.	Description
1.	—	†	Valve Assembly
2.	3372003	WES-212	ADA Compliant Dual-Flush Handle
	3372010	WES-212	ADA Compliant Dual-Flush Handle (Spanish)
3.	3308386	H-700-A	Bak-Chek® Control Stop
4.	3393007	V-600-AA	1-1/2" (38 mm) x 9" (229 mm) Vacuum Breaker Assembly †
5.	0306146	F-5-AT	1-1/2" (38 mm) Spud Coupling Assembly
6.	3308782	H-633-AA	1" (25 mm) CP Sweat Solder Kit with Cast Set Screw Flange
7.	5301139	A-31	Handle Gasket – 48 per package
8.	0372006	WES-13	Wall Plate (English)
	0372019	WES-18	Wall Plate (Spanish)

† Part number varies with valve model variation; consult factory.
 ‡ Length varies with valve model variation; consult factory.

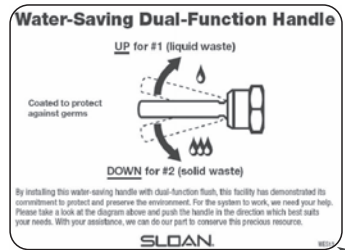

Manual Flushometers

Sloan Flushometer

Manual Flushometers

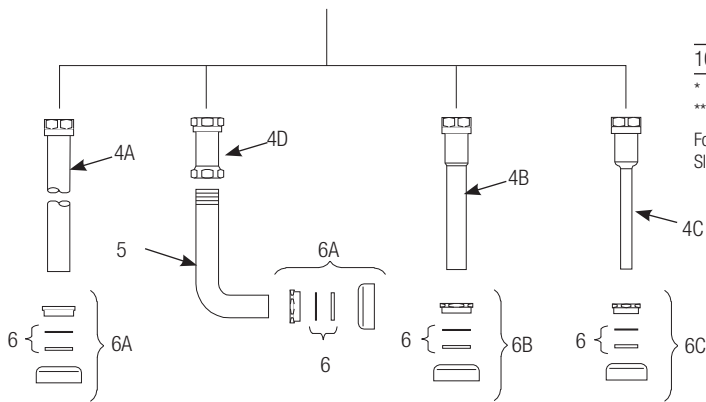
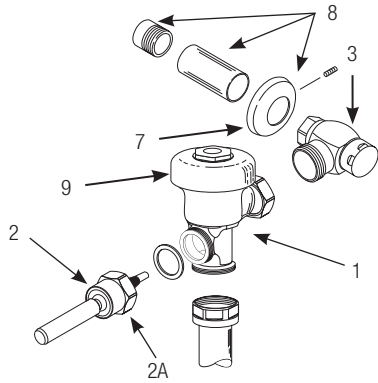

PARTS LIST

Item No.	Code No.	Part No.	Description
1.	—	A-3-A	Valve Assembly – contact Tech Support for proper assembly
2.	0302390	B-73-A	ADA Compliant Handle Assembly
2A.	0301082	A-6	CP Handle Coupling
3.	—	H-710-A	Bak-Chek® Control Stop – 3/4" or 1"
4A.	5323007	V-500-AA	1-1/2" (38 mm) x 9" (229 mm) Vacuum Breaker Assembly ** – 6 per package
4B.	5323006	V-500-AA	1-1/4" (32 mm) x 9" (229 mm) Vacuum Breaker Assembly – 6 per package
4C.	5323005	V-500-AA	3/4" (19 mm) x 9" (229 mm) Vacuum Breaker Assembly – 6 per package
4D.	—	V-500-A	Vacuum Breaker Assembly
5.	0396293	F-109	1-1/2" (38 mm) Elbow Flush Connection
6.	SEE SLIP JOINT GASKETS AND RINGS TABLE BELOW		
6A.	0306145	F-56-A	1-1/2" (38 mm) Spud Coupling Assembly
6B.	0306142	F-55-A	1-1/4" (32 mm) Spud Coupling Assembly
6C.	0306102	F-54-A	3/4" (19 mm) Spud Coupling Assembly
7.	—	F-7	Supply Flange (Supplied when Valve is not Ordered with Sweat Solder Kit)
8.	3308782	H-633-AA	1" (25 mm) Sweat Solder Kit with Cast Set Screw Flange
	3308788	H-636-AA	3/4" (19 mm) Sweat Solder Kit with Cast Set Screw Flange
9.	0378000PKSV-10		CP Sloan Cover
	0378003PKSV-10-HE		CP High Efficiency Sloan Cover
10.	3388015	H-1015	Flow Control Kit (not Shown)(HEU Only)

* Part number varies with valve model variation; consult factory.

** Length varies with valve model variation; consult factory.

For optimum water conservation and flushometer performance, use only Genuine Sloan Parts.

ITEM 6. SLIP JOINT GASKETS AND RINGS

Size	Code No.	Part No.	Description
1-1/2"	5306058	F-3	Red Friction Ring
	5322001	VBF-5	Black Slip Joint Gasket
	0319086/5319086	S-30	Flexible Seat
	0319079	S-21	Rigid Seat (rubber over brass)
1-1/2" x 1-1/4"	0396062	F-105	Slip Joint Gasket – Rigid
1-1/4"	5306057	F-3	Red Friction Ring
	5322176	VBF-5	Black Slip Joint Gasket
	0307052/5307052	G-21	Rigid Seat (rubber over brass)
1"	5306056	F-3	Red Friction Ring
	5306115	F-5	Black Slip Joint Gasket
3/4"	5306055	F-3	Red Friction Ring
	5306113	F-5	Black Slip Joint Gasket

Series 900® Flushometer

Manual Flushometers

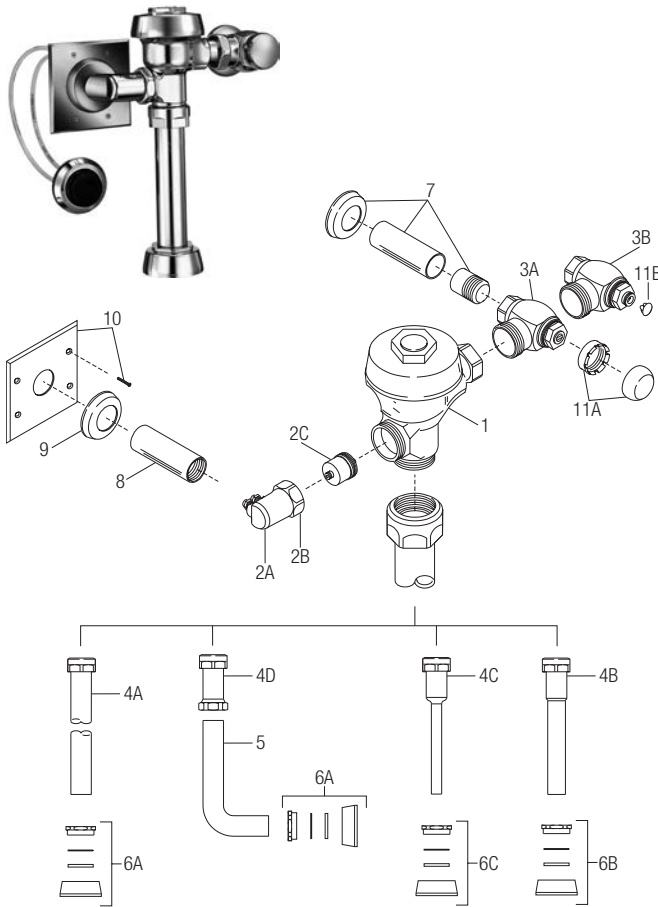

PARTS LIST FOR SERIES 900® EXPOSED FLUSHOMETER

Item No.	Code No.	Part No.	Description
1.	0301048	A-143-A	Valve Body
2A.	0318065PK	HY-65	Valve Actuator Housing
2B.	0301082PK	A-6	Housing Nut
2C.	3318001PK	HY-83-A	Actuator Cartridge Assembly
3A.	3308386	H-700-A	Bak-Chek® Control Stop (Royal Valves) for 1" 3308384 for ¾"
3B.	0388065	H-790-A	Bak-Chek® Control Stop (Regal XL Valves) for 1" 0388064 for ¾"
4A.	3893004	V-600-AA	1½" (38 mm) Vacuum Breaker Assembly
4B.	3393006	V-600-AA	1¼" (32 mm) Vacuum Breaker Assembly
4C.	3393004	V-600-AA	¾" (19 mm) Vacuum Breaker Assembly
4D.	0393003	V-600-A	Vacuum Breaker
5.	0396293	F-109	1½" (38 mm) Elbow Flush Connection
6A.	0306146	F-5-AT	1-1/2" (38 mm) Spud Coupling Assembly (Royal Valves)
	0306145	F-56-A	1½" (38 mm) Spud Coupling Assembly (Regal XL Valves)
6B.	0306140	F-5-AU	1¼" (32 mm) Spud Coupling Assembly (Royal Valves)
	0306142	F-55-A	1¼" (32 mm) Spud Coupling Assembly (Regal XL Valves)
6C.	0306125	F-5-AW	¾" (19 mm) Spud Coupling Assembly (Royal Valves)
	0306102	F-54-A	¾" (19 mm) Spud Coupling Assembly (Regal XL Valves)
7.	3308782	H-633-AA	1" (25 mm) Sweat Solder Kit & Cast Wall Flange w/ Set Screw
	3308788	H-636-AA	¾" (19 mm) Sweat Solder Kit & Cast Wall Flange w/ Set Screw
8.	0318064PK	HY-64	6" Chrome Sleeve
9.	‡	F-7	Supply Flange
10.	3318002	HY-112-A	Plate with Screws
11A.	3308772	H-1010-A	Free Spinning Vandal Resistant Stop Cap (Royal Valves)
11B.	5388002	H-528	Vandal Resistant Hole Plug (Regal Valves)

† Part number varies with valve model variation; consult factory.

‡ Length varies with valve variation; consult factory.

Dolphin® Flushometer

PARTS LIST—DOLPHIN® FLUSHOMETER MODELS AND VARIATIONS

Item No.	Code No.	Part No.	Description
1.	0337023	DO-90-AAGNC	Closet Valve Body and Handle Assembly — Dolphin Type I
	0337025	DO-90-AAGNU	Urinal Valve Body and Handle Assembly — Dolphin Type II
2A.	0388025	H-710-A	Bak-Chek® Control Stop CP with ¾" NPTF Inlet for Adjustable Tail
	0388022	H-710-A	Bak-Chek® Control Stop CP with 1" NPTF Inlet for Adjustable Tail
2B.	0388048	NH-710-AG	Bak-Chek® Control Stop w/ ¾" NPTF Inlet for Ground Joint Tail (Naval Brass; use w/ Shipboard flushometer Models Type II Class A and B; requires A-35 Reducer Bushing)
	0388058	NH-710-AG	Bak-Chek® Control Stop w/ 1" NPTF Inlet for Ground Joint Tail (Naval Brass)
	0388044	NH-710-AGS	Bak-Chek® Control Stop w/ 1" NPSM Inlet for Ground Joint Tail (Naval Brass; use w/ Shipboard flushometer Models Type I and II when Sil-Braze Adapter is used)
	0306196	F-7	1" (25 mm) Supply Flange CP (Supplied When Valve is NOT Ordered w/ Sweat Solder Kit)
	0306191	F-7	¾" (19 mm) Supply Flange CP (Supplied When Valve is NOT Ordered w/ Sweat Solder Kit)
4.	3308782	H-633-AA	1" (25 mm) Sweat Solder Kit with Cast Set Screw Flange CP ("–YBYC" Variation)
	3308788	H-636-AA	¾" (19 mm) Sweat Solder Kit with Cast Set Screw Flange CP ("–YBYC" Variation)
5A.	0323013	V-500-AA	1-½" (38 mm) x 10-½" (267 mm) Vacuum Breaker Assembly CP (Model 110/111)
	0323019	V-500-AA	1-½" (38 mm) x 23" (534 mm) Vacuum Breaker Assembly CP (Model 115)
5B1.	0396119	F-101	1-½" (38 mm) x 10-1/2" (267 mm) Outlet Tube CP Type I Class B
5B2.	0306093	F-2-AT	Coupling CP w/ S-30 gasket
5C1.†	0314004	NF-1	1-½" (38 mm) Scored Outlet CP (Shipboard Model, Type I, Class A)
5C2.‡	2104180	F-2-AT	Coupling CP w/ S-30 gasket
5D1.	0323010	V-500-A	1-½" (38 mm) Vacuum Breaker Assembly CP (Model 120 does not include F-2-A Coupling, see Item 5D2 below)
5D2.	0306092	F-2-A	Coupling CP w/ S-30 gasket
5E.†	0306850	NF-29-A	Outlet Tube Assembly ¾" (19 mm) x 6-½" (165 mm) Scored Outlet w/ ½" Offset (Shipboard Model, Type II, Class A)
5F.	0306849	NF-29-A	¾" (19 mm) x 6-½" (165 mm) Flush Connection with ½" Offset and ¾" x ½" Reducer for ½" Spud (Shipboard Model, Type II, Class B)
5G.‡	0323004	V-500-AA	¾" (19 mm) x 10-½" (267 mm) Vacuum Breaker Assembly CP (Model 186)
5H.†	0306780	F-29-A	¾" (19 mm) x 10-½" (267 mm) Flush Connection CP (Model 186–XYW)
6.†	0396302	F-109	1-½" (38 mm) Flush Connection CP
7.	SEE SLIP JOINT GASKETS AND RINGS TABLE ON BOTTOM, PAGE 30		
7A.	0306146	F-5-AT	1-½" (38 mm) Spud Coupling Assembly (Models 110/111, 115, 120)
7B.	0306125	F-5-AW	¾" (19 mm) Spud Coupling Assembly (Model 186)
8.	0306982	F-40	½" (13 mm) Sil-Braze Adapter

‡ Cut to proper length at installation. Allow a minimum of 5" (127 mm) between tube ends when using rubber hose for shock mounted equipment.

† This Outlet Tube is available in various lengths. Consult factory for assistance.

IMPORTANT NOTES

With the exception of the control stop inlet, DO NOT USE pipe sealant or plumbing grease on any valve component or coupling!

Protect the chrome or special finish of Sloan flushometers — DO NOT USE toothed tools to install or service these valves.

Use a A-50 Super-Wrench™ or smooth jawed spud wrench to secure all couplings.

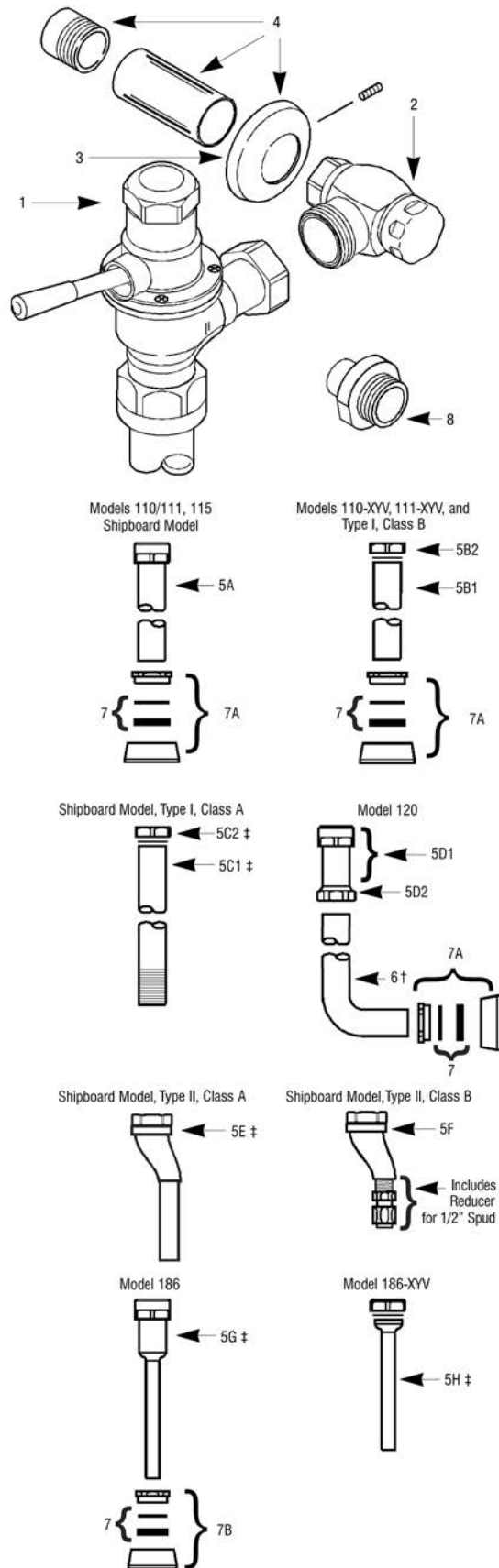

Optima® Royal® ES-S TMO Exposed Flushometers

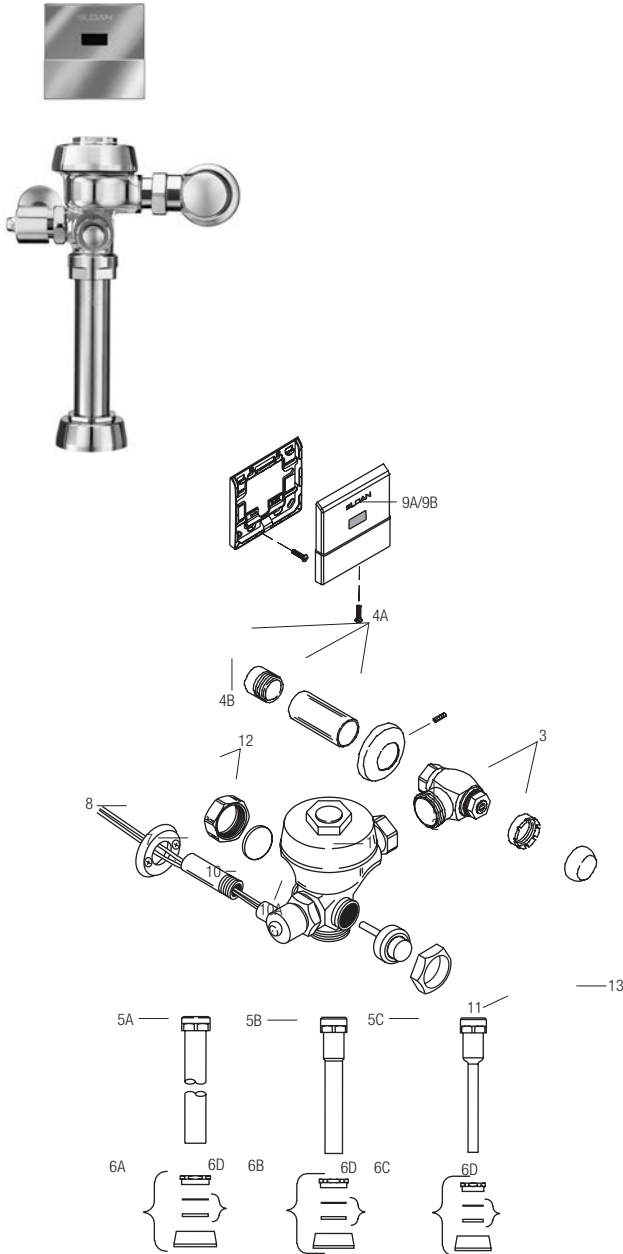

ROYAL® OPTIMA® ES-S TMO EXPOSED FLUSHOMETER PARTS LIST

Item No.	Code No.	Part No.	Description
1.	‡		Solenoid Activated Valve Assembly
2.	‡	H-700-A	Bak-Chek® Control Stop
3.	3308772	H-1010-A	Vandal Resistant Stop Cap
4A.	3308782	H-633-AA	1" (25 mm) Sweat Solder Kit
4B.	3308603	H-532	Adapter, 1" NPT to 1" Tube
	3308607	H-535.	Adapter, 3/4" NPT to 3/4" Tube
5A.	—	V-600-AA	1-1/2" (38 mm) Vacuum Breaker Assembly CP (Models 110/111, 115, and 116)
5B.	—	V-600-AA	1-1/4" (32 mm) x 9" (229 mm) Vacuum Breaker Assembly CP (Model 180 ES-S)
5C.	—	V-600-AA	3/4" (19 mm) x 9" (229 mm) Vacuum Breaker Assembly CP (Model 186 ES-S)
6A.	0306146	F-5-AT	1-1/2" (38 mm) Spud Coupling Assembly CP (Models 110/111, 115, and 116)
6B.	0306140	F-5-AU	1-1/4" (32 mm) Spud Coupling Assembly CP (Model 180)
6C.	0306125	F-5-AW	3/4" (19 mm) Spud Coupling Assembly CP (Model 186)
6D.	SEE SLIP JOINT GASKETS AND RINGS ON TABLE BELOW		
7.	‡	F-15	Tail Assembly
8.	0302323PK	B-110-A	Flange Assembly
9A.	3305107	EL-635-A	CP Cover Plate with Sensor (Mounting Plate and Screws included) (Models 110/111, 115, and 116)
9B.	3305101	EL-645-A	CP Cover Plate with Sensor (Mounting Plate and Screws included) (Models 180 and 186)
10.	0305329	EL-124-2	CP 24V Solenoid Assembly Only
10A	3305043	EL-128-A	Actuator Cartridge Assembly Only
	3305045	EL-1028-A	Solenoid Assembly w/ Cartridge Assembly
11.	0303009	C-2-A	True Mechanical Override Button
12.	3325814	EBV-1017-A	CP Valve Handle Cap
13.	0301082PK	A-6	CP Nut
—	3345080	EL-1026-A	ES-S to ES-S-TMO Conversion Kit Exposed includes Body/Tail assembly (no inside parts or covers) #11, #12, #13, DO-22 and EL-110 o-rings
—	3305043	EL-128-A	Actuator Cartridge
14.	3302306	B-51-A	Triple Seal Handle Repair Kit
15.	3345080	EL-126-A	ESS to TMO Retrofit Conversion Kit (Exposed*)
	3388015	H-1015-A	Flow Control Kit (HEU Only (not Shown))

‡ Part number varies with valve model variation; consult factory.

* Not shown

ITEM 6D. SLIP JOINT GASKETS AND RINGS

Size	Code No.	Part No.	Description
1-1/2"	5306058	F-3	Red Friction Ring
	5322001	VBF-5	Black Slip Joint Gasket
	0319086/5319086	S-30	Flexible Seat
	0319079	S-21	Rigid Seat (rubber over brass)
1-1/2" x 1-1/4"	0396062	F-105	Slip Joint Gasket – Rigid
1-1/4"	5306057	F-3	Red Friction Ring
	5322176	VBF-5	Black Slip Joint Gasket
	0307052/5307052	G-21	Rigid Seat (rubber over brass)
1"	5306056	F-3	Red Friction Ring
	5306115	F-5	Black Slip Joint Gasket
3/4"	5306055	F-3	Red Friction Ring
	5306113	F-5	Black Slip Joint Gasket

SLOAN ECOS® Hardwired Flushometers

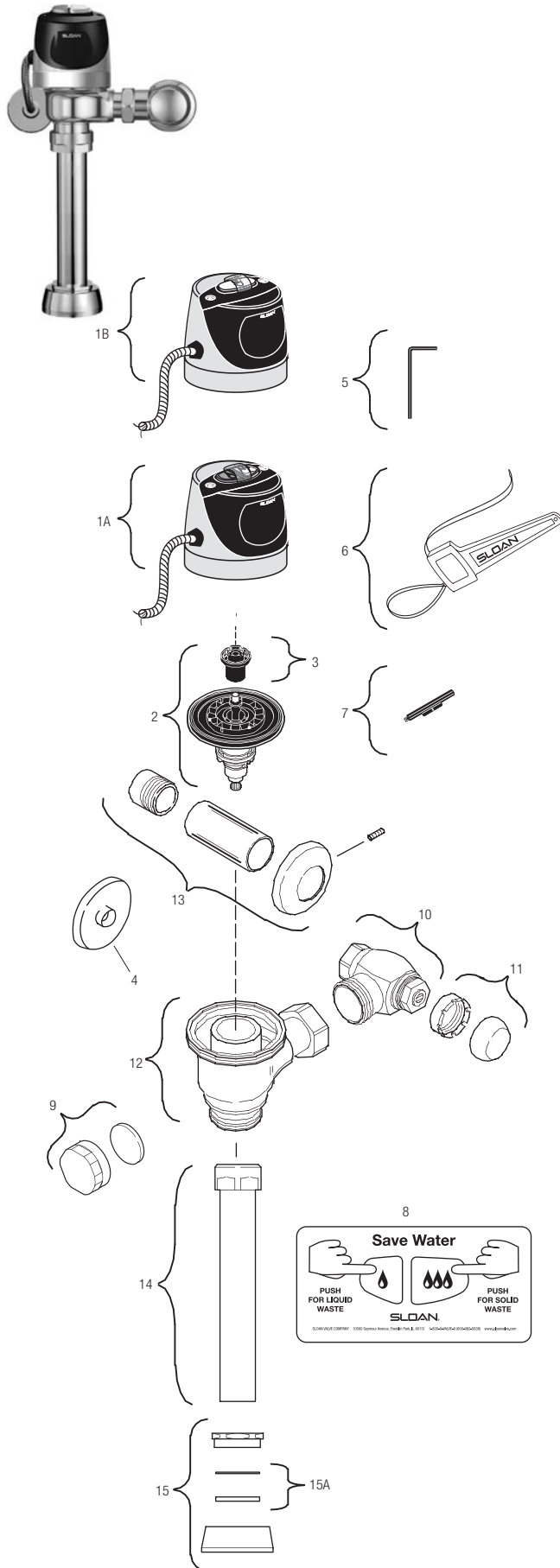

PARTS LIST

Item No.	Code No.	Part No.	Description
Items Included with the RESS Retrofit and Complete Sloan ECOS® Hardwire Valves Only			
1A.	‡	—	Sloan ECOS® Electronic Hardwire Dual Flush Assembly
1B.	‡	—	Sloan ECOS® Electronic Single-Flush Assembly
2.	3325001	EBV-1020-A	1.6 gpf/6.0 Lpf Closet Flex Tube Diaphragm Kit
3.	5325122	EBV-95	Flush Volume Regulator (Green)
4.	—	EL-612-A	Solenoid Wall Flange
5.	0325159	EBV-137	7/64" Hex Wrench
6.	0305823	EBV-22	Strap Wrench
7.	0325194	EBV-91	Range Adjustment Tool
8.	0372031	WES-19	English Operation Instruction Plate
	0372040	WES-22	Spanish Operation Instruction Plate
9.	3325814	EBV-1017-A	Handle Cap (RESS-C Retrofit Models only)
Items Included with the Complete Sloan ECOS® Hardwire Valves Only			
10.	3308386	H-700-A	1" (25 mm) Bak-Chek® Control Stop
11.	3308797	H-1010-A	Vandal Resistant Stop Cap
12.	0305381PK	EBV-36-A	Valve Body
13.	3308782	H-633-AA	1" (25 mm) Sweat Solder Kit
14.	3308782	V-600-AA	1½" (38 mm) x 10" (254 mm) Vacuum Breaker (Model 110)
	—	V-600-AA	1½" (38 mm) x 23" (584 mm) Vacuum Breaker (Model 115)
	0393049	V-600-AA	1½" (38 mm) x 26" (660 mm) Vacuum Breaker (Model 116)
15.	0306146	F-5-AT	1½" Spud Coupling Assembly (Models 111, 115, and 116)
15A.	SEE SLIP JOINT GASKETS AND RINGS TABLE BELOW		

‡ Part number varies with valve model variation; consult factory.

The EBV-1020-A Kit is supplied with multiple Flush Volume Regulators. The installer must use the correct Regulator when installing the kit.

ITEM 15A. SLIP JOINT GASKETS AND RINGS

Size	Code No.	Part No.	Description
1-1/2"	5306058	F-3	Red Friction Ring
	5322001	VPF-5	Black Slip Joint Gasket
	0319086/5319086	S-30	Flexible Seat
	0319079	S-21	Rigid Seat (rubber over brass)
1-1/2" x 1-1/4"	0396062	F-105	Slip Joint Gasket – Rigid
1-1/4"	5306057	F-3	Red Friction Ring
	5322176	VPF-5	Black Slip Joint Gasket
	0307052/5307052	G-21	Rigid Seat (rubber over brass)
1"	5306056	F-3	Red Friction Ring
	5306115	F-5	Black Slip Joint Gasket
3/4"	5306055	F-3	Red Friction Ring
	5306113	F-5	Black Slip Joint Gasket

FLEX TUBE DIAPHRAGM ASSEMBLY



Sloan ECOS® Electronic Valve Models Feature Sloan's Exclusive Flex Tube Diaphragm for the ultimate in valve performance, reliability and chloramine resistance.

Sensor Flushometers

Sloan ECOS® Single-Flush and Dual-Flush Flushometers

Sensor Flushometers

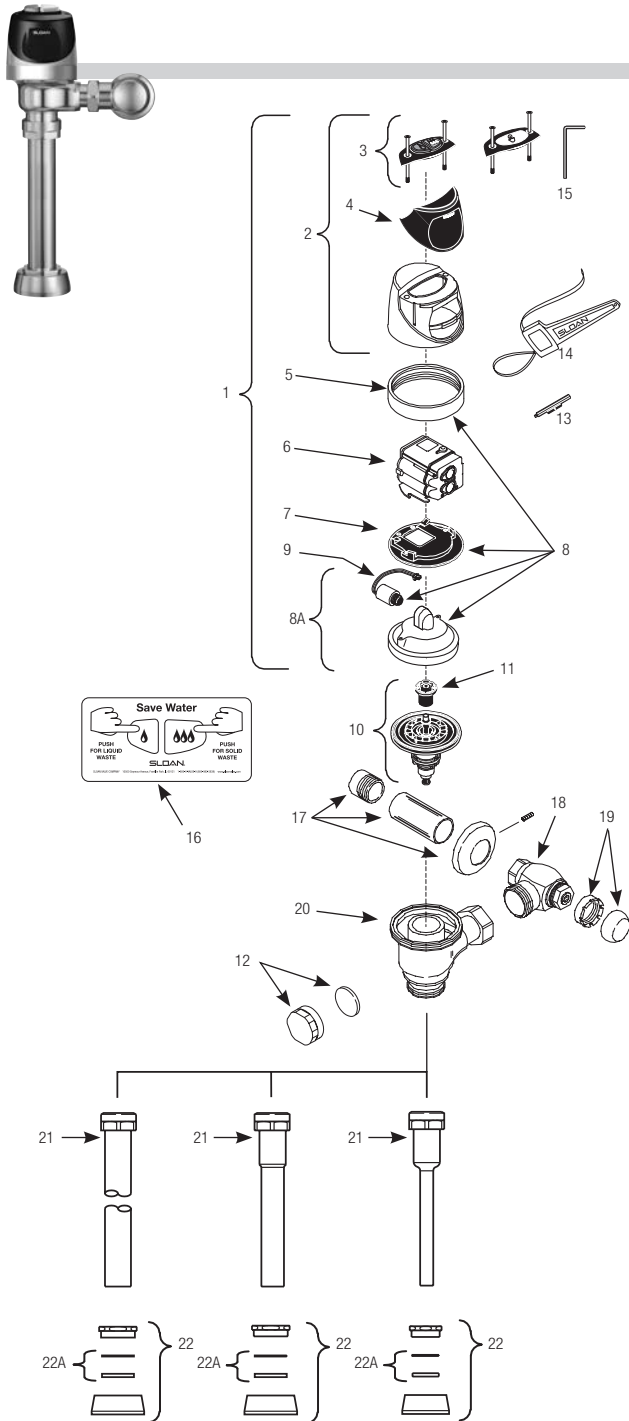

FLEX TUBE DIAPHRAGM ASSEMBLY



Sloan ECOS® Electronic Valve Models Feature Sloan's Exclusive flex tube diaphragm™ for the ultimate in valve performance, reliability and chloramine resistance.

Items Included with Complete Sloan ECOS Valves Only

Item.	Code.	Part #	Description
22A	0306146	F-5-AT	1½" Spud Coupling Assembly (Water Closet Models)
22B	0306125PK	F-5-AW	¾" Spud Coupling Assembly (Urinal Models)

† Part No. varies with valve model variation; consult factory.
22C. **SEE SLIP JOINT GASKETS AND RINGS TABLE ON NEXT PAGE**

Item.	Code.	Part #	Description
Items Included with RESS Retrofit and Complete Sloan ECOS Flush Valves			
1	0372055	WES-55-A	Cover/Ring/Sensor Assembly - Dual Flush WC
	0325160	EBV-138-A	Cover/Ring/Sensor Assembly - 1.6 & 1.28 gpf Single Flush WC
	—	EBV-378-A	Cover/Ring/Sensor Assembly - 1.1 gpf Single Flush WC
	0325161	EBV-139-A	Cover/Ring/Sensor Assembly - 1.0 gpf Single Flush Urinal
	0325341	EBV-341-A	Cover/Ring/Sensor Assembly - 0.5 gpf Single Flush
	0325329	EBV-329-A	Cover/Ring/Sensor Assembly - 0.25 gpf Single Flush
	0325273	EBV-324-A	Cover/Ring/Sensor Assembly - 0.125 gpf Single Flush
	0372060	WES-60-A	Cover/Ring/Sensor Assembly w/ Zurn ring - Dual Flush WC
	0325166	EBV-149-A	Cover/Ring/Sensor Assembly w/ Zurn ring 1.6 & 1.28 gpf Single Flush Water Closet
	0325167	EBV-150-A	Cover/Ring/Sensor Assembly w/ Zurn Ring Single Flush Urinal
2	0325246	EBV-191-A	Cover Assembly - Dual Flush
	0325168	EBV-142-A	Cover Assembly - Single Flush
3A	0372033	WES-23-A	Button Cover Assembly with Screws - Dual Flush
	0325172	EBV-130-A	Button Cover Assembly with Screws - Single Flush
	0325242	EBV-182-A	Button Cover Assembly L/OR w/ Screws
3B	0325170	EBV-132-A	Screws (2) and Hex Wrench Only
4	0325169	EBV-131	Lens Window Cover
5	0325210PL	EBV-168	Locking Ring
	0325214PK	EBV-172	Locking Ring - for Zurn valves
6	0325247	EBV-196-A	Module - ECOS Electronic 1.6/1.1 gpf Dual Flush
	—	EBV-383-A	Module - ECOS Electronic 1.1 gpf Single Flush
	3325450	EBV-129-AC	Module - ECOS Electronic 1.6 & 1.28 gpf Single Flush
	0325395	EBV-386 AU	Single Flush 0.125 gpf/0.5 Lpf
	0325396	EBV-387 AU	single Flush 0.25 gpf/1.0 Lpf
	3325451	EBV-129-AU	Module - ECOS Electronic 0.5 & 1.0 gpf Single Flush
7	0325171	EBV-134	Cover Rest Plate
8	3325089	EBV-1010-A	Inner Cover Repair Kit (Metal)
8A	3325456	EBV-145-A	Inside Cover Assembly (includes solenoid)
9	3325453	EBV-136-A	Solenoid
10A	†		Flex Tube Diaphragm Assembly
10B	†		Cartridge Assembly
11	†		Flush Volume Regulator
12	3325814	EBV-1017-A	Handle Cap (RESS Retrofit Models only)
13	0325194	EBV-91	Range Adjustment Tool
14	0305823	EBV-22	Strap Wrench
15	0325159	EBV-137	7/64" Hex Wrench
16	0372031	WES-19	English Operation Instruction Plate
	—	WES-22	Spanish Operation Instruction Plate
17.	3388015	H-T015	Flow Control Kit (HEU Only) (Not Shown)
Items Included with Complete Sloan ECOS Valves Only			
17A	3308782	H-633-AA	1" (25 mm) Sweat Solder Kit
17B	3308788	H-636-AA	¾" (20 mm) Sweat Solder Kit
18A	0388000	H-700-A	1" (25 mm) Bak-Chek® Control Stop
18B	0388001	H-700-A	¾" (20 mm) Bak-Chek® Control Stop
19	3308797	H-1010-A	Vandal Resistant Stop Cap
20	0305381PK	EBV-36-A	Valve Body
21A	3393002	V-600-AA	1½" (38 mm) x 10" (254 mm) Vacuum Breaker (Model 8110)
	0323044	V-600-AA	1½" (38 mm) x 23" (584 mm) Vacuum Breaker (Model 8115)
	0393049	V-600-AA	1½" (38 mm) x 26" (660 mm) Vacuum Breaker (Model 8116)
21B	0323117	V-600-AA	¾" (20 mm) x 10" (254 mm) Vacuum Breaker (Model 8186)

The EBV-1020-A Kit is supplied with multiple Flush Volume Regulators. The installer must use the correct Regulator when installing the kit.

SOLIS® Single-Flush and Dual-Flush Flushometer

Sensor Flushometers

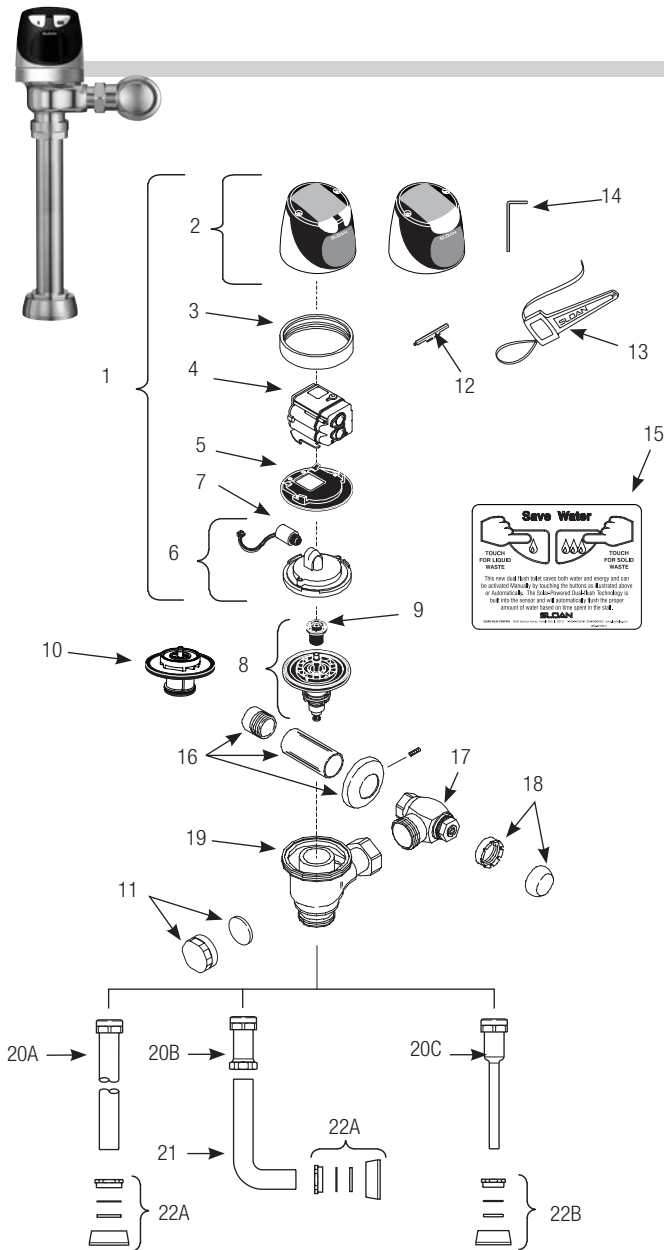

Item.	Code.	Part.	Description
-------	-------	-------	-------------

Items Included with RESS Retrofit and Complete Sloan SOLIS® Valves

1	0325300	EBV-304-A	Cover/Sensor/Assembly - Closet SOLIS 1.6 & 1.28 gpf Electronic Single Button Flush
	—	EBV-379-A	Cover/Sensor/Assembly - Closet SOLIS 1.1 gpf Electronic Single Button Flush
	0372024	WES-24-A	Cover/Sensor/Assembly - Closet SOLIS Electronic Dual Flush
	0325301	EBV-306-A	Cover/Sensor/Assembly - Urinal 0.5 & 1.0 gpf SOLIS Electronic Single Button
	0325328	EBV-328-A	Cover/Sensor/Assembly - Urinal 0.25 gpf SOLIS Electronic Single Button
	0325302	EBV-325-A	Cover/Sensor/Assembly - Urinal 0.125 gpf SOLIS Electronic Single Button
	0325320	EBV-320-A	Cover/Sensor/Assembly (Zurn) - Closet 1.6 & 1.28 gpf SOLIS Electronic Single Button Flush
	0372028	WES-28-A	Cover/Sensor/Assembly (Zurn) - Closet SOLIS Electronic Dual Flush
	0325321	EBV-321-A	Cover/Sensor/Assembly (Zurn) - Urinal 0.25 gpf SOLIS Electronic Single Button
2	0325311	EBV-311-A	Cover Assembly - SOLIS Electronic Dual Flush Flush
	0325309	EBV-309-A	Cover Assembly - SOLIS Electronic Single Button Flush
3	0325804	EBV-14	Locking Ring
	0305843	EBV-30	Locking Ring - for Zurn valves
4	0325312	EBV-312-A-C	Module - SOLIS - Water Closet
	0325313	EBV-312-A-U	Module - SOLIS - Urinal
	—	EBV-382-A	Module - SOLIS - 1.1 gpf Single Button Flush
	0372038	WES-33-A	Module - SOLIS - Water Closet (Dual Flush)
5	0325171	EBV-134	Cover Rest Plate
6	3325456	EBV-145-A	Inside Cover Assembly (includes solenoid)
7	3325453	EBV-136-A	Solenoid
8	†		Flex Tube Diaphragm Assembly
9	†		Flush Volume Regulator
10	†		Cartridge Assembly
11	3325814	EBV-1017-A	Handle Cap (RESS Retrofit Models Only)
12	0325107	EBV-91	Range Adjustment Tool
13	0305823	EBV-22	Strap Wrench
14	0325159	EBV-137	7/64" Hex Wrench
15	0372029	WES-27	English Plate (Dual Flush only)
	0372025	WES-29	Spanish Plate (Dual Flush only)

Items Included with Complete Sloan SOLIS® Valves Only

16	3308782	H-633-AA	1" (25 mm) Sweat Solder Kit
	3308788	H-636-AA	¾" (19 mm) Sweat Solder Kit
17	3308386	H-700-A	1" (25 mm) Bak-Chek® Control Stop
	3308384	H-700-A	¾" (19 mm) Bak-Chek® Control Stop
18	3325089	H-1010-A	Vandal Resistant Stop Cap
19	0305381	EBV-36-A	Valve Body
20A	—	V-600-AA	1½" (38 mm) x 10½" (229 mm) Vacuum Breaker (Model 8111)
	—	V-600-AA	1½" (38 mm) x 15" (584 mm) Vacuum Breaker (Model 8113)
	—	V-600-AA	1½" (38 mm) x 23" (584 mm) Vacuum Breaker (Model 8115)
	—	V-600-AA	1½" (38 mm) x 26" (660 mm) Vacuum Breaker (Model 8116)
20B	—	V-600-A	3" (76 mm) Vacuum Breaker Assembly
20C	—	V-600-AA	¾" (19 mm) x 10½" (229 mm) Vacuum Breaker (Model 8186)
21	—	F-109	1½" (38 mm) Elbow Flush Connection
22A	0306146	F-5-AT	1½" Spud Coupling Assembly (Models 8110, 8110 8115 & 8116)
22B	0306125	F-5-AW	¾" Spud Coupling Assembly (Model 8186)

† Part No. varies depending on flushometer model.

Manufactured in the U.S.A. by Sloan Valve Company under one or more of the following patents: U.S. Patents: D598,975; D599,436; 7,124,997. Other Patents Pending. BAK-CHEK®, PARA-FLO®, PERMEX®, TURBO-FLO®.

Sweat Solder Kits

SWEAT SOLDER KITS

Item			
No.	Code No.	Part No.	Description
H-533-A			
1	3308603	H-532	1" Adapter*
1, 2, 5	3308780	H-533-AS	Sweat Solder Kit W/Stamped Wall Flange for 1" Supply-Closet & Urinal
1-4	3308794	H-533-AC	Sweat Solder Kit W/Cast Wall Flange for 1" Supply-Closet & Urinal
2	—	H-534	1 3/8" Casing Tube for 1" Copper
H-534-A			
1	3308603	H-532	1" Adapter*
1, 2, 5	3308783	H-534-AS	Sweat Solder Kit W/Stamped Wall Flange for 1" Supply-Closet & Urinal 3" Tube
1-4	3308796	H-534-AC	Sweat Solder Kit W/Cast Wall Flange for 1" Supply-Closet & Urinal
2	—	H-534	Casing Tube for 1" Copper
H-536-A			
1	3308607	H-535-A	3/4" Adapter*
1, 2, 5	3308786	H-536-AS	Sweat Solder Kit W/Stamped Wall Flange for 3/4" Supply-Closet & Urinal
1-4	3308798	H-536-AC	Sweat Solder Kit W/Cast Wall Flange for 3/4" Supply-Closet & Urinal
2	—	H-537	1 1/8" Casing Tube for 3/4" Copper

Note: H-532-AS, H-533-AS, H-534-AS, H-535-AS and H-536-AS are also identified as suffix YB when furnished with flush valve.

All Tube lengths- 2"

*Furnished separate for concealed installations.

Item			
No.	Code No.	Part No.	Description
H-633-AA			
1	3308603	H-532	1" Adapter
1-4	3308782	H-633-AA	Sweat Solder Kit for 1" Supply – Urinal 3" Tube
2	—	H-534	Casing Tube for 1" Copper
H-634-AA			
1	3308603	H-532	1" Adapter
1-4	3308785	H-634-AA	Sweat Solder Kit for 1" Supply – Closet 6" Tube
2	—	H-534	Casing Tube for 1" Copper
H-636-AA			
1	0308607	H-535	3/4" Adapter
1-4	3308788	H-636-AA	Sweat Solder Kit for 3/4" Supply – Urinal
2	—	H-537	Casing Tube for 3/4" Copper

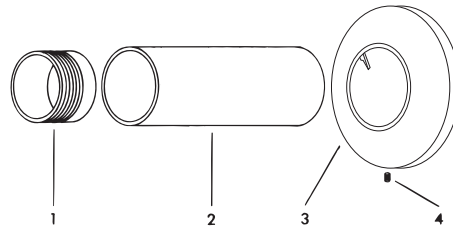
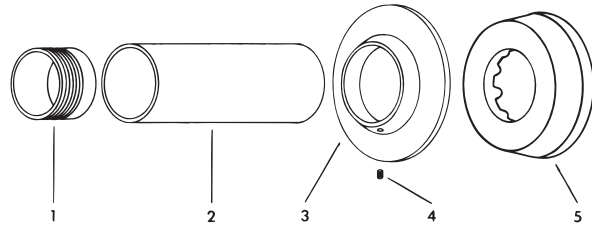

Showerheads, Parts and Accessories