



SERVICE PARTS LIST

BULLETIN NO.
54-05-0642

SPECIFY CATALOG NO. AND SERIAL NO. WHEN ORDERING PARTS		REVISED BULLETIN 54-05-0641	DATE Aug. 2013
DOUBLE INSULATED HEAT GUN			
CATALOG NO.	8975-6	SERIAL NUMBER	731A
		WIRING INSTRUCTION See Reverse Side	

EXAMPLE:
Component Parts (Small #) Are Included
When Ordering The Assembly (Large #).

★ = Part number change from
previous service parts list.

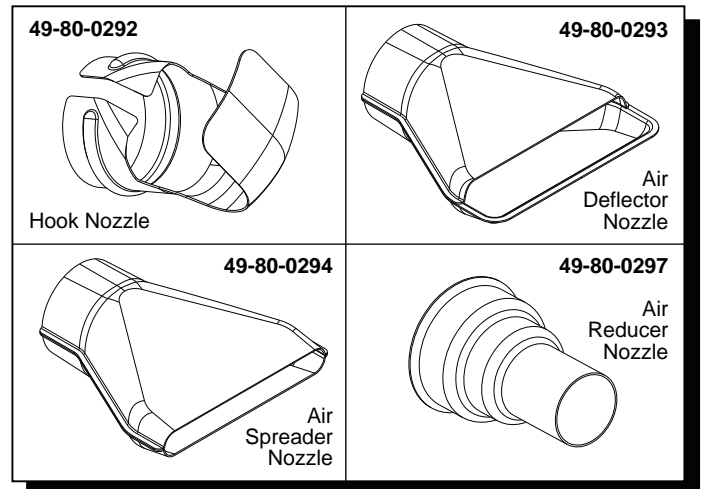
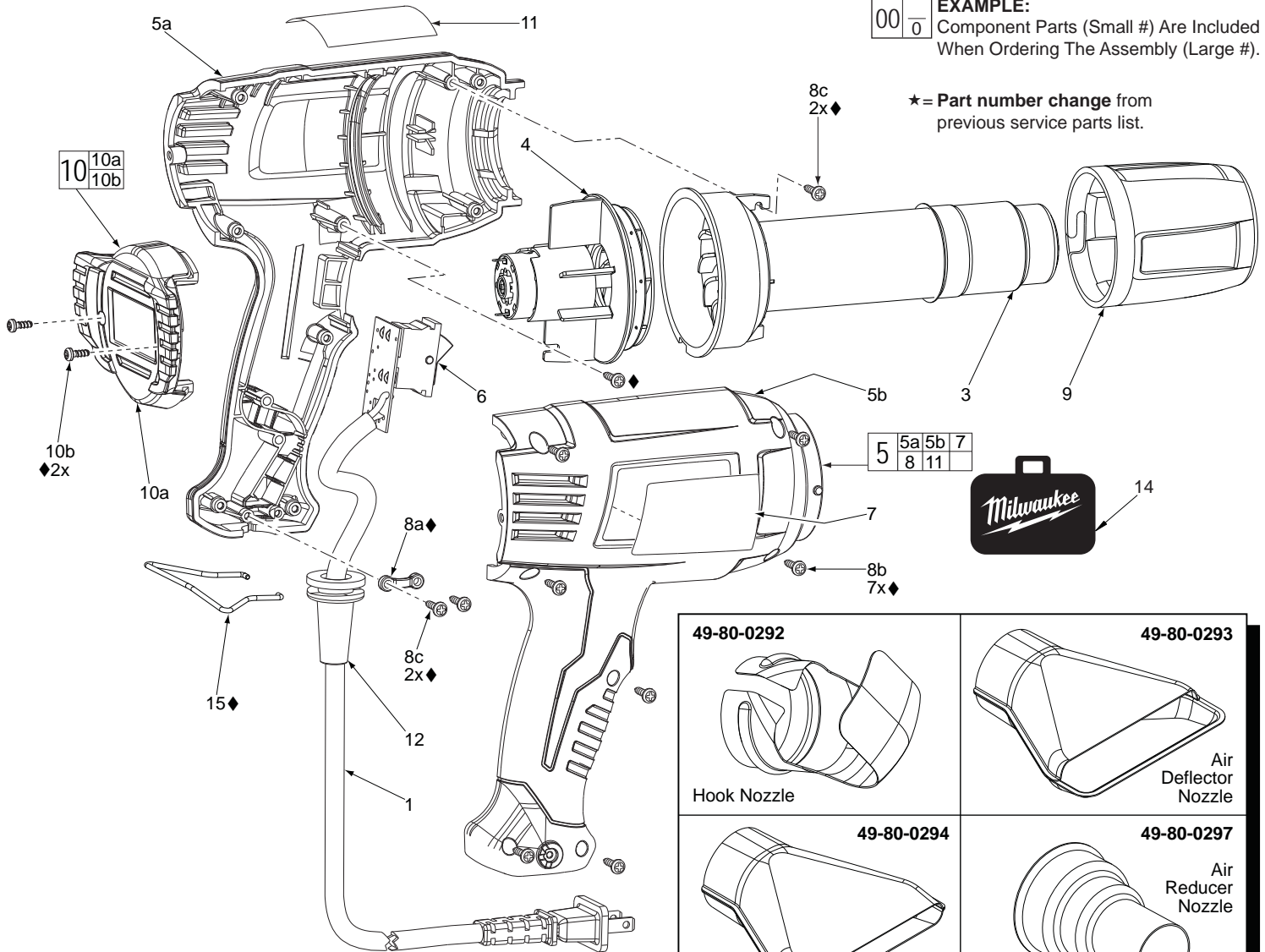

Cat. No. 49-80-0300
Heat Gun Accessory Assortment
Includes the four accessories listed above.

FIG.	PART NO.	DESCRIPTION OF PART	NO. REQ.
★ 1	22-64-8975	Cord Set	(1)
★ 3	-----	Heating Element Assembly	(1)
★ 4	14-46-8974	Motor and Fan Assembly	(1)
★ 5	14-46-8977	Handle Service Kit	(1)
★ 5a	-----	Left Handle Halve	(1)
★ 5b	-----	Right Handle Halve	(1)
★ 6	-----	Switch/PCBA	(1)
★ 7	12-20-8975	Service Nameplate Kit	(1)
★ 8	14-46-8979	Repair Service Kit (Includes all ♦ items)	(1)
★ 8a	-----♦	Cord Clamp	(1)
★ 8b	-----♦	M3 x 13 Phillips Pan Hd. Screw	(7)
★ 8c	-----♦	M3 x 13 Phillips Pan Hd. Screw	(4)
★ 9	44-90-8975	Nose Shield	(1)
★ 10	31-12-8975	End Cap Service Kit	(1)
★ 10a	-----	End Cap	(1)
★ 10b	-----♦	M3.5 x 8 Phillips Pan Hd. Screw	(2)
★ 11	10-20-0112	Warning Label	(1)
★ 12	44-76-8975	Strain Relief	(1)
★ 14	42-55-8975	Carrying Case	(1)
★ 15	-----♦	Wire Tool Support	(1)

8 ♦ 14-46-8979 Repair Service Kit				
Consists of:				
Fig.	Description of Part	Where Used	Color	Qty.
10b	M3.5 x 8 Phillips Pan Hd. Screw	End Cap	Black	2
8b	M3 x 13 Phillips Pan Hd. Screw	Right Handle	Black	7
8c	M3 x 13 Phillips Pan Hd. Screw	Heating Element	Chrome	2
8c	M3 x 13 Phillips Pan Hd. Screw	Cord Clamp	Chrome	2
15	Wire Tool Support	Handle Halves	-----	1
8a	Cord Clamp	Left Handle	-----	1

