



SERVICE PARTS LIST

BULLETIN NO.
54-24-3300

SPECIFY CATALOG NO. AND SERIAL NO. WHEN ORDERING PARTS		REVISED BULLETIN	DATE
M12™ BRUSHLESS 1/2" (13mm) HAMMER-DRILL			Feb. 2014
CATALOG NO.	2404-20	WIRING INSTRUCTION	
STARTING SERIAL NO.	E28A		

EXAMPLE:
Component Parts (Small #)
Are Included When Ordering
The Assembly (Large #).

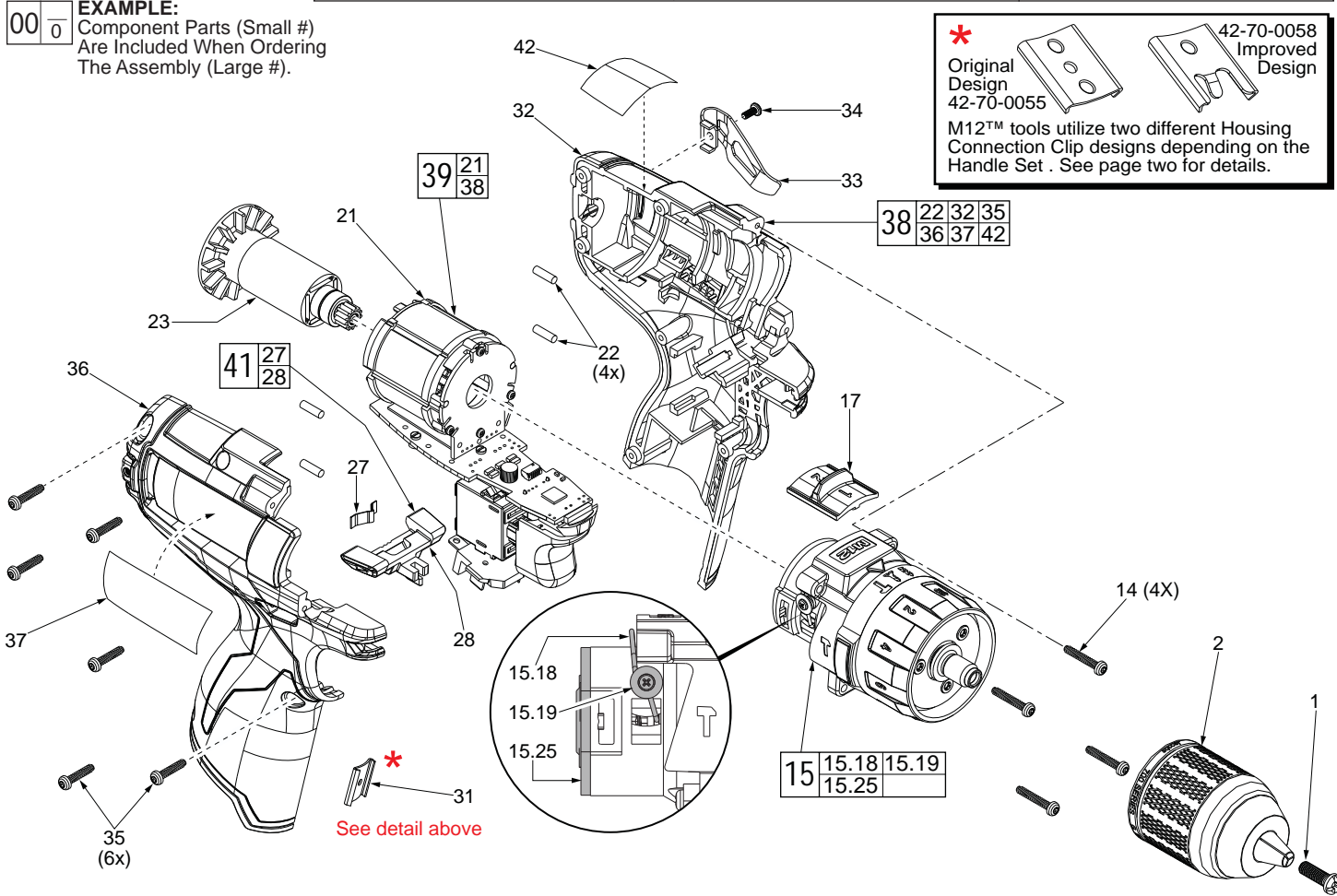
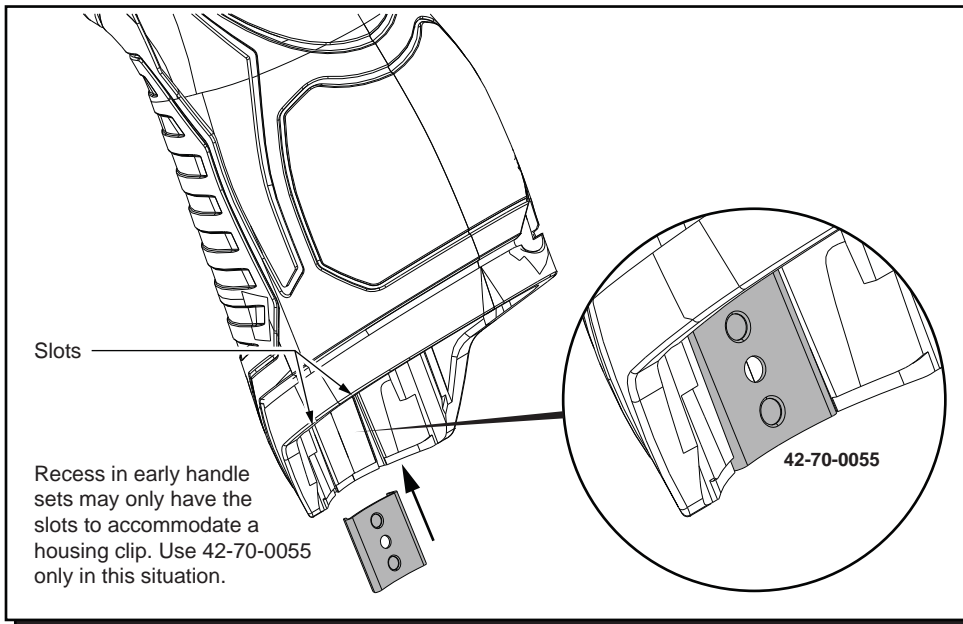

FIG.	PART NO.	DESCRIPTION OF PART	NO. REQ.
1	05-88-1500	M6 x 1.0 x 27mm LH Chuck Screw	(1)
2	42-66-0200	1/2" (13mm) Keyless Chuck	(1)
14	05-88-0780	M3 x 18mm T-10 ST Screw (Gearcase)	(4)
15	14-29-0560	Gearcase Assembly	(1)
15.18	44-10-0710	Speed Selector Lever	(1)
15.19	05-81-0542	M2.3 x 4.5mm ST Screw	(2)
15.25	-----	Motor Mounting Plate	(1)
17	45-24-0325	Speed Selector Button	(1)
21	-----	Motor / Switch / PCBA Assembly	(1)
22	45-30-0270	Rubber Pin	(4)
23	16-07-0400	Service Rotor	(1)
27	40-50-1135	Shuttle Spring	(1)
28	42-42-0610	Forward / Reverse Shuttle	(1)
31	42-70-1150	Housing Connection Clip	(1)
32	-----	Left Housing Half	(1)
33	42-70-0580	Belt Clip	(1)
34	05-88-1010	M2.5 x 6mm Screw	(1)
35	06-82-1080	M3 x 14mm T-10 ST Scr (Handle Halves)	(6)
36	-----	Right Housing Half	(1)
37	12-20-2402	Service Nameplate	(1)
38	31-44-2025	Housing Kit	(1)
39	14-20-1130	Housing / Electronics Kit	(1)
40	42-55-2100	Blow Molded Carrying Case	(1)
41	42-42-1120	Forward / Reverse Shuttle Kit	(1)
42	10-20-2399	Warning Label (French & Spanish)	(1)

Apply Blue Loctite® thread locking sealant or the equivalent to the threads of the chuck screw (1) before securing chuck to the gearcase spindle.



SCREW TORQUE SPECIFICATION CHART			
FIG.	PART NO.	DESCRIPTION	SEATING TORQUE (IN-LBS)
1	05-88-1500	Chuck Screw	33±2.5
15.19	05-81-0542	Speed Selector Lever Screw	3.5±1
14	05-88-0780	Gearcase Assembly Screw	7.0±2.5
35	06-82-1080	Right Housing Half Screw	7.0±2.5



Early M12™ Handle Sets utilize **Housing Connection Clip No. 42-70-0055**. Install this clip design by aligning the side rails of the clip with the two slots in the handle set. Gently push into place with the aid of a small flat blade screwdriver or a similar instrument. Be sure that the clip is properly seated in both slots and that the clip is flush to sub-flush to the end of the handle set. To remove the clip, use the same small flat blade screwdriver or a similar instrument and push the clip out of the handle set. If the clip is loose or will not stay in place, a needle nose pliers can be used to gently bend/pinch the side rails of the clip. If the clip is damaged do not use, replace with a new 42-70-0055 housing clip.

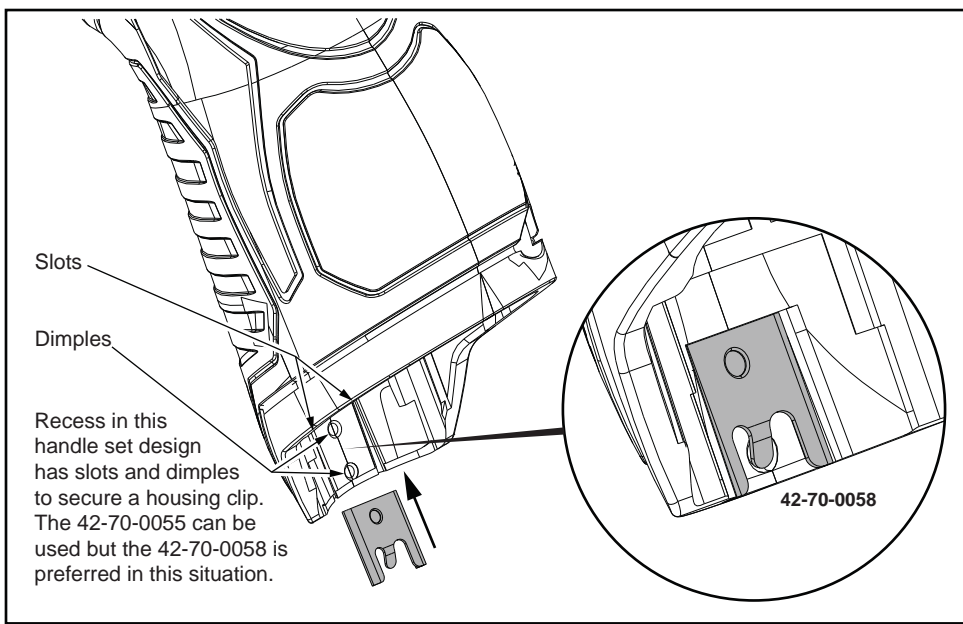

Updated M12™ Handle Sets utilize **Housing Connection Clips No. 42-70-0055 and 42-70-0058**. (The 42-70-0058 is a preferred upgrade). Install this clip design by aligning the side rails of the clip with the two slots in the handle set. Gently push into place with the aid of a small flat blade screwdriver or a similar instrument. Be sure that the clip is properly seated in both slots and that the tab of the clip snaps down in the round dimpled cavity of the handle set. Be sure that the clip is flush to sub-flush to the end of the handle set. To remove the clip, use the same small flat blade screwdriver or a similar instrument and lift up on the clip tab while pushing the clip out of the handle set. Use a needle nose pliers to gently rebend the clip tab if necessary. If the tab on the clip is damaged during this process and is loose or will not stay in place, replace with a new 42-70-0058 clip.

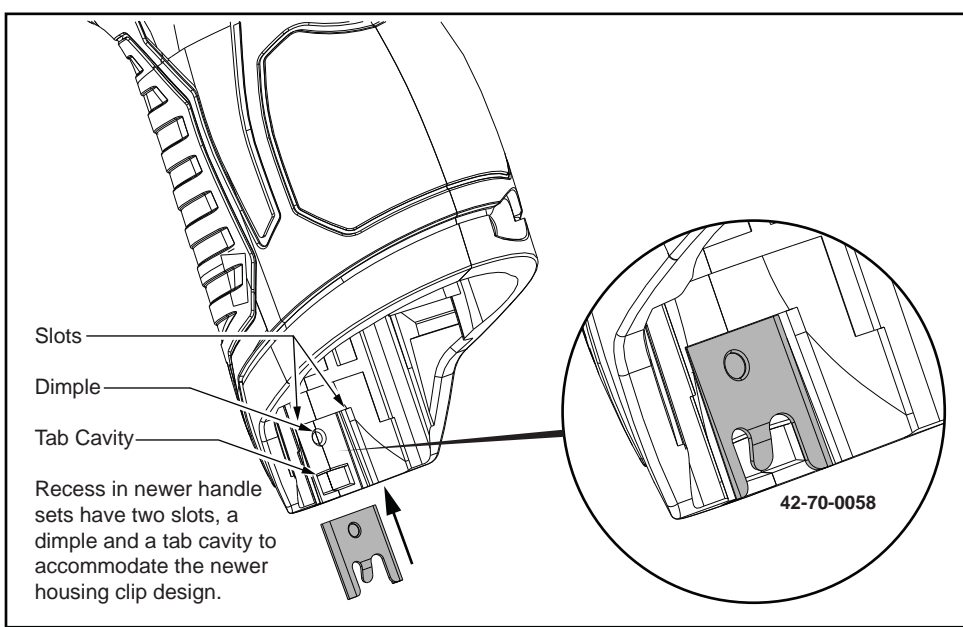

Newer M12™ Handle Sets utilize **Housing Connection Clip No. 42-70-0058**. Install this clip design by aligning the side rails of the clip with the two slots in the handle set. Gently push into place with the aid of a small flat blade screwdriver or a similar instrument. Be sure that the clip is properly seated in both slots and that the tab of the clip snaps down in the rectangular cavity of the handle set. Be sure that the clip is flush to sub-flush to the end of the handle set. To remove the clip, use the same small flat blade screwdriver or a similar instrument and lift the clip tab out of the cavity while pushing the clip out of the handle set. Use a needle nose pliers to gently rebend the clip tab if necessary. If the tab on the clip is damaged during this process and is loose or will not stay in place, replace with a new 42-70-0058 clip.