



SERVICE PARTS LIST

BULLETIN NO.
54-05-0095

SPECIFY CATALOG NO. AND SERIAL NO. WHEN ORDERING PARTS		REVISED BULLETIN	DATE
M12™ HAND VACUUM			Jan. 2015
CATALOG NO.	0850-20	STARTING SERIAL NO. G37A	
WIRING INSTRUCTION			

EXAMPLE:

00	0
----	---

 Component Parts (Small #) Are Included
 When Ordering The Assembly (Large #).

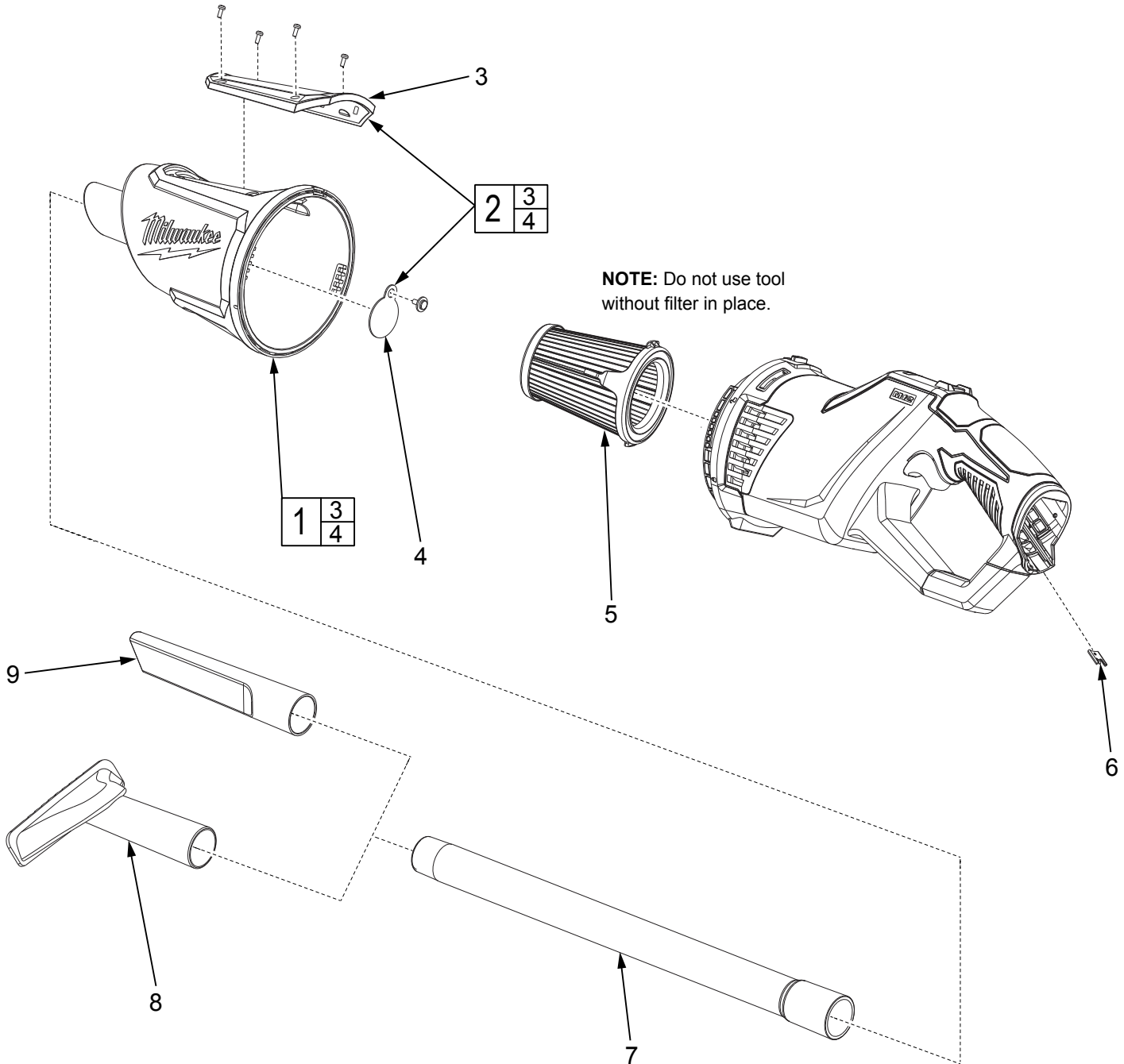

FIG.	PART NO.	DESCRIPTION OF PART	NO. REQ.
1	42-51-0500	Canister Assembly	(1)
2	45-80-0350	Flapper Valve/Lens/Screw Kit	(1)
3	-----	Lens with Screws	(1)
4	-----	Flapper Valve with Screw	(1)
5	49-90-1950	Dry Filter Kit	(1)
6	42-70-0058	Housing Connection Clip	(1)
7	45-76-1000	Extension Tube	(1)
8	31-01-0870	Utility Nozzle	(1)
9	31-01-0850	Crevice Tool	(1)
10	12-20-0845	Service Nameplate (Not Shown)	(1)
11	10-20-1103	Warning Label (Not Shown)	(1)

FIG. NOTES
 3,4 These parts can be purchased together as a kit (Fig. 2) or as components parts of the Canister Assembly (Fig. 1).
 10 A clean, dry surface is essential for proper performance for any adhesive system. The area intended for application of any adhesive label or nameplate must be prepared by cleaning with isopropyl alcohol. The solvent is to be applied with a clean, lint free applicator and the surface allowed to dry before applying the label or nameplate.